

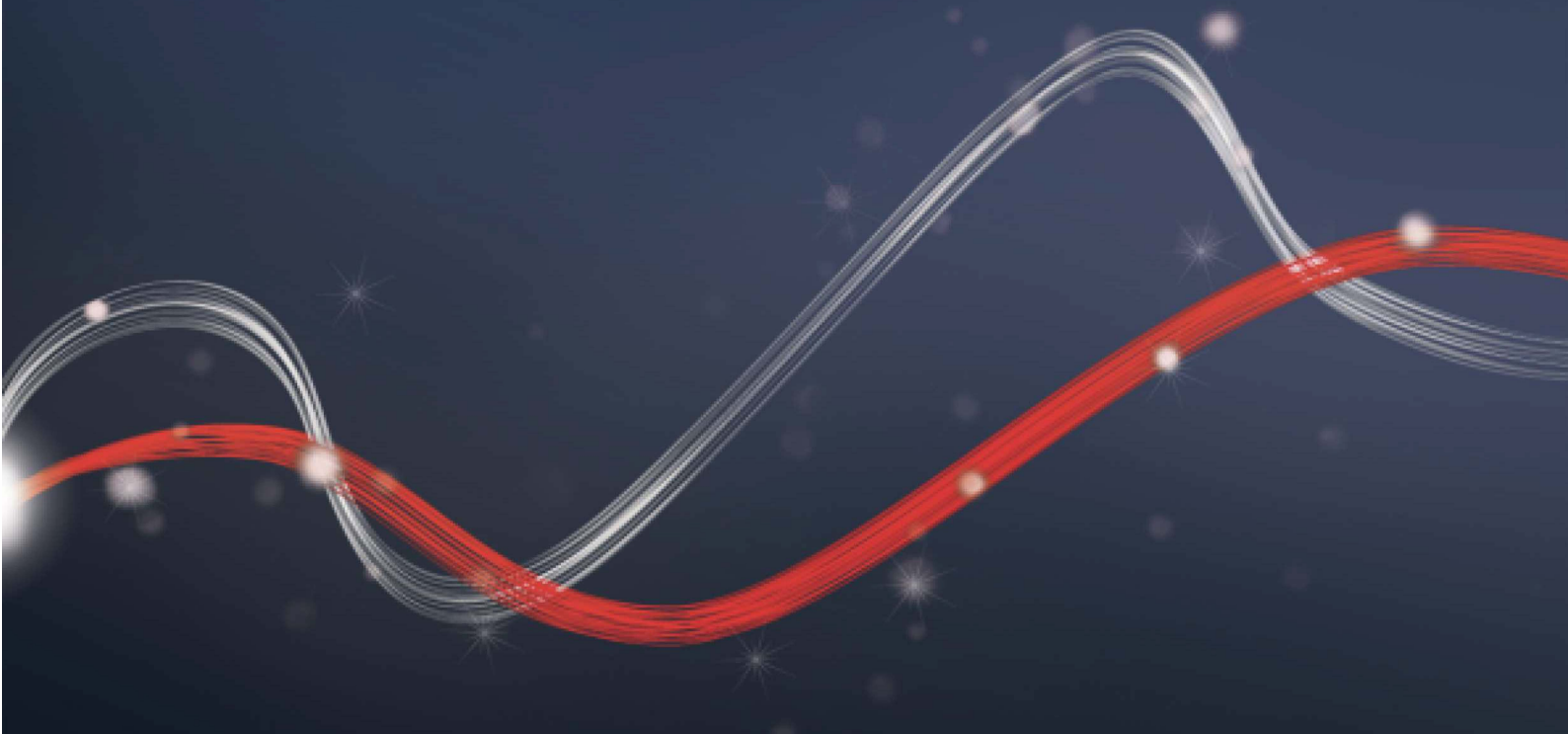

Be ahead



ECOSOL





Solar power supply system

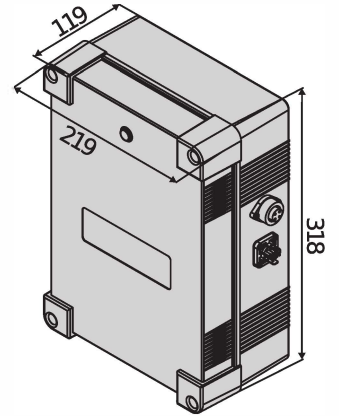
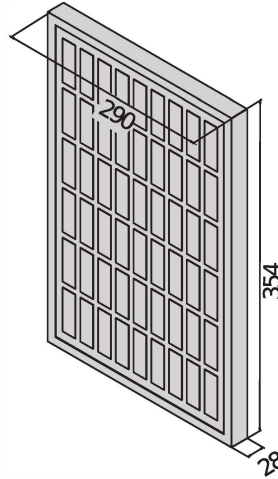

Ecocol is a complete solar powered system for low-voltage installations. Ideal for doors and gates that are not easily reached from the power mains, it adapts to any context thanks to compatibility with all 24V systems, both old and new.

Relevant features



The system components are interconnected with sealed, quick-fit connectors to ensure maximum simplicity in daily use.



The control panels have a useful handle to make them easy to carry when they have to be connected to the electricity mains to recharge the batteries.



"Vandal-proof" versions of screws and fasteners can be supplied to guarantee maximum security and safety in all situations.







Solar power supply system

ECOSOL

Code	CI	Name	Description
D113731	2609201	ECOSOL BOX	Control and management unit for solar power supply of systems with supply voltage of 24 V. Batteries included.
D113750	2609221	ECOSOL BOX NO BATTERY	Control and management unit for supplying solar power to systems with supply voltage of 24 V. Batteries not included.
N999471	2611114	ECOSOL PANEL	Solar-powered system compatible with BFT systems only

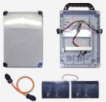
	ECOSOL BOX	ECOSOL BOX NO BATTERY	ECOSOL PANEL
Nominal voltage	24 V	24 V	24 V
Maximum current	10 A	10 A	no A
Peak power	no Wp	no Wp	10 Wp
Battery nominal capacity	7,2 Ah	7,2 Ah	no Ah
Battery type	12 A	12 A	no A
Maximum panel power	35 Wp	35 Wp	35 Wp
Consumption in standby	0,15 W	0,15 W	no W
Protection rating	IP55	IP55	IP65
Environmental conditions	-20 ÷ 50 °C	-20 ÷ 50 °C	-20 ÷ 50 °C

RECOMMENDED ACCESSORIES

	Cp D113732 - Ci 2609213 ECOSOL DOUBLE Expansion board with batteries Included		Cp N999473 - Ci 2611115 ECOSOL POST BR Set of stainless steel screws and brackets for installing the ECOSOL PANEL on a post of diameter 48-100mm
	Cp N999475 - Ci 2611116 ECOSOL SECURITY Anti-tamper stainless steel screws and fasteners for ECOSOL PANEL and ECOSOL POST BR		Cp N999476 - Ci 2611231 ECOSOL CABLE 20 m extension for ECOSOL CHARGER
	Cp N999477 - Ci 2611118 ECOSOL CHARGER Battery chargers for ECOSOL BOX and ECOSOL DOUBLE		



Solar power supply system

EasyAXS

EASY CONNECT. EASY ACCESS.



The new connectivity solution which boosts the potential of BFT products and services to make access automations smarter and easier to use for both installers and end users.





Solar power supply system

EASY TO CONNECT

WIFI MODULE



→ 10/15 metres

WIFI MODULE
+ ANTENNA

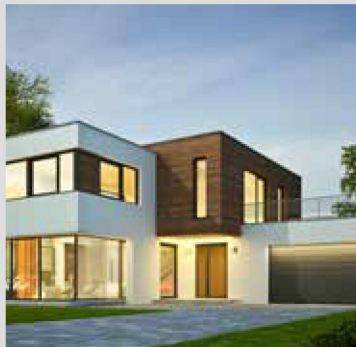

→ 20/25 metres

MOBILE MODULE
+ ANTENNA + SIM



→ ∞



**PLUG&PLAY
INSTALLATION**



**ALWAYS
CONNECTED**



**EVEN MORE
CONNECTIVITY**



**EASY TO SET UP
FOR INSTALLERS**



**EASY TO CONTROL
FOR CUSTOMERS**





Solar power supply system



U-LINK 2.0

AN UPDATED VERSION OF U-LINK TO GIVE YOU EVEN MORE FUNCTIONALITY



Scalable

You can add as many devices as you want

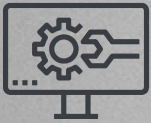

Intuitive

Easy to install and to use



Functional

Settings can be controlled and firmware updated remotely using dedicated applications



Practical

Works with or without an internet connection



Flexible

It allows you to create groups of interconnected products

U-Link, the exclusive **BFT** technology platform has evolved to offer improved interaction with the latest generation of technological ecosystems. Its ability to interface with all home access automation access devices has been expanded, meaning it is now a very useful tool for installers. It is also a faster communication protocol with increased security for communicating information.

It allows you to save even more time, checking everything very easily and giving you even more peace of mind.



Solar power supply system

U-SECURITY

A NEW AND EVEN MORE SECURE RADIO PROTOCOL



- **Secure**
By transmitting data protected by a cryptographic key

U-Security is the new technology from **BFT** which incorporates encrypted rolling code thanks to the encryption key which masks the remote control code, meaning that it is impossible to clone a BFT remote control using another brand's model.

The functions of the **Er Ready** system are incorporated and a new procedure is also available for programming remote controls by scanning a QR CODE and using a special app. All products featuring this technology are **REPLAY**, so they can transmit the code to another BFT remote control using a combination of keys.



- **Easy**
Pairing a remote control with a receiver can be done easily by scanning the QR code and using the dedicated app



- **Universal**
The radio protocol is also compatible with the previous generation of receivers

