

ARES ULTRA 1500 BT UL

RANGE

Electromechanical automation for rack sliding gates up to 75'

ARES ULTRA 1500 BT UL

P926191 00005 – ARES ULTRA BT A1500 120V – Gates up to 3,300lbs.

P926192 00005 – ARES ULTRA FAST 1500 120V – Gates up to 1,750lbs.



- ARES 1500 operators widen the BFT range of sliding gate operators. Rated with the “medium-heavy” weight range, they integrate with existing products to obtain an operator that is perfectly suited to the gate every time.

LOW VOLTAGE MOTOR

- The 24V electrical motor guarantees maximum accuracy in torque and speed control. It is suitable for intensive gate use. Optional battery back-up can be fitted within the operator casing. These operators are all “Ecosol” solar compatible.



TECHNICAL FEATURES

	ARES 1500 Fast	ARES 1500 Standard
Control panels	TWD (incorporated)	TWD (incorporated)
Reversible/irreversible operator	irreversible	irreversible
Power supply	120 V 60 Hz single-phase	120 V 60 Hz single-phase
Absorbed power	240W	400W
Thermal protection	integrated	integrated
Leaf Speed	8.0 ips	5.9 ips
Pinion Pitch	4 mm (18 teeth)	4 mm (18 teeth)
Impact reaction	electronic torque limiter	electronic torque limiter
Manual release	Lever-operated with key	Lever-operated with key
Operating cycle	intensive use	intensive use
Environmental conditions	-4°F to 131°F	-4°F to 131°F
Degree of protection	IP44	IP44
Operator weight	20 lbs	20 lbs
Limit switches	magnetic	magnetic

ARES ULTRA 1500 BT UL

DIMENSIONS

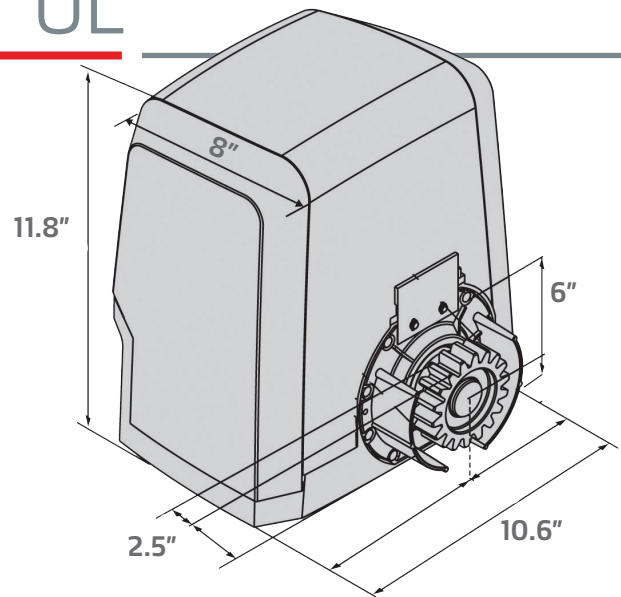

ACCESSORIES



P125035 SL BAT 2
24V DC Battery Back up for Deimos Ares Ultra charger board and battery backup supply cassette plug in

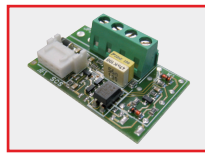

P111468 B EBA SERIAL BOARD
Two serial connection interfaces required for MERAK UL board primary and secondary connections.



D221073-CP
22x22 4mm-pitch plastic rack with adjustment slots. 3' 3" length.

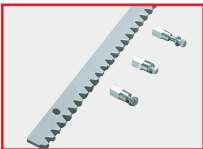

D571053 CVZ
30x12 4mm pitch galvanised adjustable steel rack 3' 3" length. Box of 10



I0096728 25 TEETH PINION
Larger pinion for increased speed (7.9ips). Max gate weight Ares 1000 1100lb (500Kg) & Ares 1500 1650lb (750Kg).



N999629 MITTO 4 RAINBOW
4 X 4 CH Mitto Transmitters- White, Blue, Burgundy & Yellow
4 button remote control
433 Mgtz

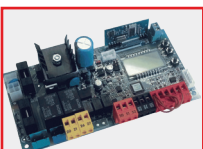

I700139 10001 MERAK ARES BT ULTRA UL 120V
Replacement Control Board



D111904 MITTO 2 TRANSMITTER:
12V Two channel 433Mhz rolling code remote control



P121024 QB Touch
Digital keypad with 10 channels and 100 combinations. Backlit



KED113731H ECOSOL KIT
Includes Ecosol Interface, solar panel and 15' solar of panel cable, connection harness for easy installation, for running BFT control panels off 24V solar power. Includes two 12V 7.2Ah batteries and circuit board for management of commands to control panel and battery charge management, with built-in Rolling Code 433.92 MHz receiver with 63 stored positions.

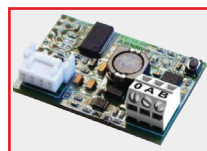

P111494: B EBA WIFI GATEWAY
For use with U Control App for open/ closing BFT gate systems with smart phone app or GPS. Wifi connection access at gate required.



Be ahead