

Phobos N L BT

installation manual
version 130308

Thalia control board

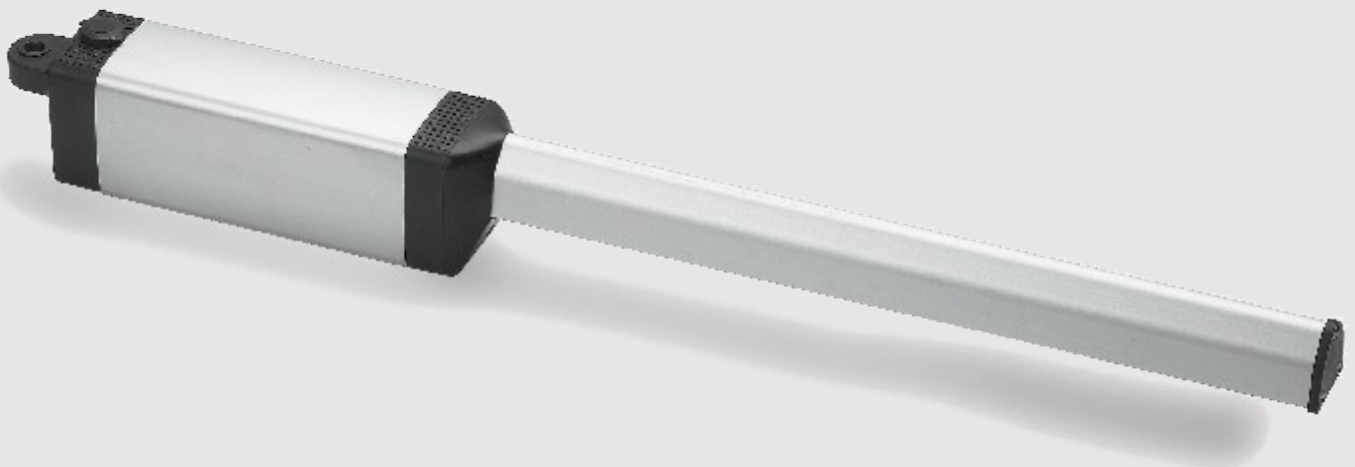

tuned to you

Professional installation required
welding might be needed

GATE AUTOMATION INSTALLATION SAFETY

While the manufacturer has designed the system under strict safety standards, it is ultimately the installers responsibility to follow and comply with national and local laws, codes and safety standards that apply to the mechanical, electrical and operational aspects of the gate automation system. These include but are not limited to: safety standards established by entities like Underwriters Laboratory (UL), NFPA 70, or codes and laws stated by corresponding state, county or municipality.

While it may not be compulsory, we highly recommend following UL 325 safety standards.

UL 325 VEHICULAR GATE AUTOMATION CLASSIFICATION

This system can be used in Class I, Class II and Class III applications.

- **CLASS I – RESIDENTIAL VEHICULAR GATE OPERATOR** - A vehicular gate operator (or system) intended for use in a home of one-to four single family dwelling, or a garage or parking area associated therewith.
- **CLASS II – COMMERCIAL/GENERAL ACCESS VEHICULAR GATE OPERATOR** - A vehicular gate operator (or system) intended for use in a commercial location or building such as a multi-family housing unit (five or more single family units), hotel, garages, retail store, or other building servicing the general public.
- **CLASS III – INDUSTRIAL/LIMITED ACCESS VEHICULAR GATE OPERATOR** - A vehicular gate operator (or system) intended for use in an industrial location or building such as a factory or loading dock area or other locations not intended to service the general public.
- **CLASS IV – RESTRICTED ACCESS VEHICULAR GATE OPERATOR** - A vehicular gate operator (or system) intended for use in a guarded industrial location or building such as an airport security area or other restricted access locations not servicing the general public, in which unauthorized access is prevented via supervision by security personnel.

UL 325 ENTRAPMENT PROTECTION REQUIREMENTS

For all installation classes, it is required to properly adjust the inherent obstruction sensing system and install warning signs on both sides of the gate, warning pedestrians of the dangers of the automated gate system. For Class I and Class II installations, it is required to add a non-contact device, such as a photoelectric eye **OR** a contact device such as a gate edge. For Class III installations it is required to add a non-contact device, such as a photoelectric eye, **AND** a contact device such as a gate edge **OR** an audio alarm such as a siren, horn or buzzer.

UL325 INSTALLATION RECOMMENDATIONS

1. Install the gate operator only when:
 - a. The operator is appropriate for the construction and the usage class of the gate.
 - b. All openings of a horizontal slide gate are guarded or screened from the bottom of the gate to a minimum of 4' (1.2 m) above the ground to prevent a 2-1/4" (6 cm) diameter sphere from passing through the openings anywhere in the gate, and in that portion of the adjacent fence that the gate covers in the open position.
 - c. All exposed pinch points are eliminated or guarded, and guarding is supplied for exposed rollers.
2. The operator is intended for installation only on gates used for vehicles. Pedestrians must be supplied with a separate access opening. The pedestrian access opening shall be designed to promote pedestrian usage. Locate the gate such that persons will not come in contact with the vehicular gate during the entire path of travel of the vehicular gate.
3. The gate must be installed in a location so that enough clearance is supplied between the gate and adjacent structures when opening and closing to reduce the risk of entrapment. Swinging gates shall not open into public access areas.
4. The gate must be properly installed and work freely in both directions prior to the installation of the gate operator.
5. Controls intended for user activation must be located at least six feet (6') away from any moving part of the gate and where the user is prevented from reaching over, under, around or through the gate to operate the controls. Outdoor or easily accessible controls shall have a security feature to prevent unauthorized use.
6. The Stop and/or Reset (if provided separately) must be located in the line-of-sight of the gate. Activation of the reset control shall not cause the operator to start.
7. A minimum of two (2) WARNING SIGNS (supplied with the gate operator) shall be installed, one on each side of the gate where easily visible.
8. For a gate operator utilizing a non-contact sensor:
 - a. Reference owner's manual regarding placement of non-contact sensor for each type of application.
 - b. Care shall be exercised to reduce the risk of nuisance tripping, such as when a vehicle trips the sensor while the gate is still moving.
 - c. One or more non-contact sensors shall be located where the risk of entrapment or obstruction exists, such as the perimeter reachable by a moving gate or barrier.
9. For a gate operator utilizing a contact sensor such as an edge sensor:
 - a. One or more contact sensors shall be located where the risk of entrapment or obstruction exists, such as at the leading edge, trailing edge and post mounted both inside and outside of a vehicular horizontal slide gate.
 - b. One or more contact sensors shall be located at the bottom edge of a vehicular vertical lift gate.
 - c. A hard wired contact sensor shall be located and its wiring arranged so the communication between the sensor and the gate operator is not subject to mechanical damage.
 - d. A wireless contact sensor such as the one that transmits radio frequency (RF) signals to the gate operator for entrapment protection functions shall be located where the transmission of the signals are not obstructed or impeded by building structures, natural landscaping or similar obstruction. A wireless contact sensor shall function under the intended end-use conditions.
 - e. One or more contact sensors shall be located on the inside and outside leading edge of a swing gate. Additionally, if the bottom edge of a swing gate is greater than 6" (152 mm) above the ground at any point in its arc of travel, one or more contact sensors shall be located on the bottom edge.
 - f. One or more contact sensors shall be located at the bottom edge of a vertical barrier (arm).

GENERAL SAFETY

WARNING! An incorrect installation or improper use of the product can cause damage to persons, animals or property.

- Automation should be installed on a gate which is moving freely. Any issue with the smooth opening or closing of a gate will not be corrected by adding automation.
- Scrap packing materials (plastic, cardboard, polystyrene etc) according to the provisions set out by current standards. Keep nylon or polystyrene bags out of children's reach.
- Keep this instruction manual for future reference.
- This product was exclusively designed and manufactured for the use specified in the present documentation. Any other use not specified in this documentation could damage the product and be dangerous.
- The Company declines all responsibility for any consequences resulting from improper use of the product, or use which is different from that expected and specified in the present documentation.
- Do not install the product in explosive atmosphere.
- The Company declines all responsibility for any consequences resulting from failure to observe Good Technical Practice when constructing closing structures (door, gates etc.), as well as from any deformation which might occur during use.
- Follow and comply with national and/or local electrical codes when performing any electrical installation.
- Disconnect the electrical power supply before carrying out any work on the installation. Also disconnect any buffer batteries, if fitted.
- Fit all the safety devices (photocells, electric edges etc.) which are needed to protect the area from any danger caused by squashing, conveying and shearing, according to and in compliance with the applicable directives and technical standards.
- It is recommended to position at least one luminous signal indication device (blinker) where it can be easily seen for additional safety
- The Company declines all responsibility with respect to the automation safety and correct operation when other manufacturer's components are used.
- Only use original parts for any maintenance or repair operation.
- Do not modify the automation components, unless explicitly authorized in writing by the Company.
- Instruct the product user about the control systems provided and the manual opening operation in case of emergency.
- Anything which is not expressly provided for in the present instructions, is not allowed.
- Installation must be carried out using the safety devices and controls prescribed by the UL 325 Standard.

CHECKING INSTALLATION

Before the automated device is finally put into operation, perform the following checks meticulously:

- Make sure all components are fastened securely.
- Check that all safety devices (photocells, pneumatic safety edge, etc.) are working properly.
- Check the emergency operation control device.
- Check opening and closing operations with the control devices applied.
- Check the electronic logic for normal (or personalized) operation in the control panel.

ADJUSTING OPERATING FORCE

WARNING: Operating force is adjusted with extreme precision by means of the control unit's electronic control. Operation at the end of travel is adjusted electronically in the control panel. To provide good anti-crush safety, the operating force must be slightly greater than that required to move the leaf both to close and to open it.

CONTROL

There are various options when it comes to the control system (manual, remote control, access control with magnetic badge, etc.) depending on the installation's needs and characteristics. See the relevant instructions for the various control system options. People due to use the automated device must be instructed how to control and use it.

OPERATIONAL SAFETY

The installer is responsible for communicating the following information to the end-user:

This product has been designed and built solely for the purpose indicated herein. Uses not contemplated herein might result in the product being damaged and could be a source of danger.

The Firm disclaims all responsibility resulting from improper use or any use other than that for which the product has been designed, as indicated herein, as well as for failure to apply Good Practice in the construction of entry systems (doors, gates, etc.) and for deformation that could occur during use. If installed and used correctly, the automated system will meet the required level of safety. Nonetheless, **it is advisable to observe certain rules of behavior so that accidental problems can be avoided:**

- Keep adults, children and property out of range of the automated system, especially while it is operating.
- Operate the system when the full path of the gate is within sight.
- It is essential to frequently check that all safety devices are in good working condition.
- This application is not meant for use by people (including children) with impaired mental, physical or sensory capacities, or people who do not have suitable knowledge, unless they are supervised or have been instructed by people who are responsible for their safety.
- Children must be supervised to ensure they do not play with the system. Keep remote controls or other control devices out of reach of children in order to avoid the automated system being operated inadvertently.
- Check the system frequently, especially hinges, cables, springs or supports, to detect any loss of balance and signs of wear or damage.
- When cleaning the outside or performing other maintenance work, always cut off mains power.
- Keep the photocells' optics and illuminating indicator devices clean. Check that no branches or shrubs interfere with the safety devices (photocells).
- Do not use the automated system if it is in need of repair. In the event of a malfunction, cut off the power, activate the emergency release to allow access and call in qualified technical personnel (professional installer).
- If the automated system requires work of any kind, employ the services of qualified personnel (professional installer).
- Anything that is not explicitly provided for in these instructions is not allowed.
- The operator's proper operation can only be guaranteed if the information given herein is complied with. The Firm shall not be answerable for damage caused by failure to comply with the installation rules and instructions featured herein.
- Have the complete system checked including all safety devices by a qualified professional technician at least once a year.

Descriptions and illustrations herein are not binding. While we will not alter the product's essential features, the Firm reserves the right, at any time, to make those changes deemed necessary to improve the product from a technical, design or commercial point of view, and will not be required to update this publication accordingly.

Installation Safety	2
Operational Safety	3
Applications and Capacities	5
Post Bracket Installation.....	6
Gate Bracket Installation.....	7
Push to Open Installation.....	8
Actuator Cable.....	9
Mounting the Actuator.....	10
Setting the Limits.....	11
Installing the Standard Control Box.....	12
Installing the Optional Control Box.....	13
Motor Connections.....	14
Quick Setup Menu.....	15
Presets.....	17
Accessory Connections.....	19
Accessory Power	
Command Inputs	
Safety Devices.....	20
Safety Loop Detector Wiring	
Auxiliary Outputs.....	21
Shadow Loop Detector Wiring	
Navigating the Main Menu.....	22
Programming Menu.....	23
Other Accessories Connections.....	24
Magnetic Lock Wiring	
Battery Backup Wiring	
Maintenance.....	25
Manual operation	
Common Error Codes	
Replacement Parts.....	26
Options & Accessories.....	27
At A Glance Quick Reference.....	28



Important. This product is intended to be installed and serviced by a professional technician. The product warranty may be voided if installed or serviced by a unqualified person.

Phobos NL BT

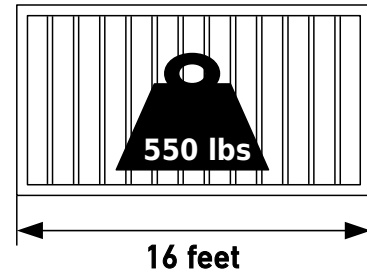
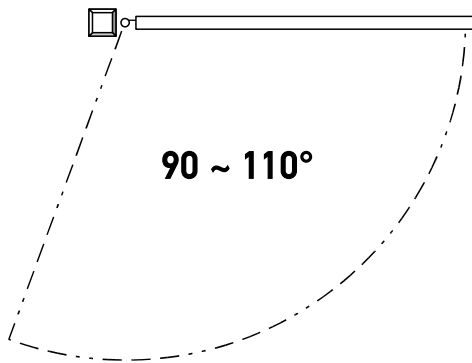
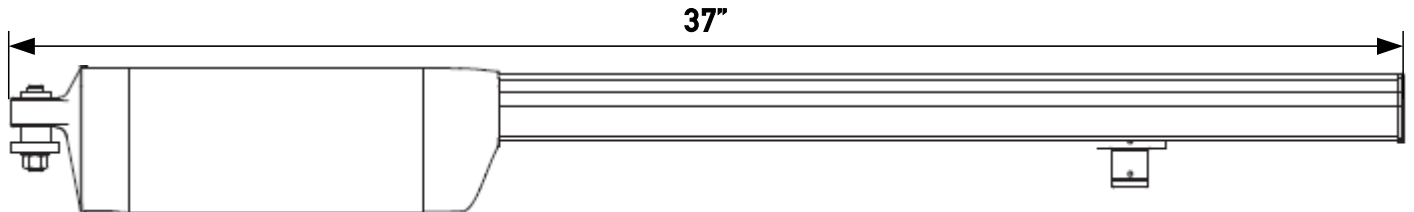

an external locking mechanism is suggested for gates over 10 feet long

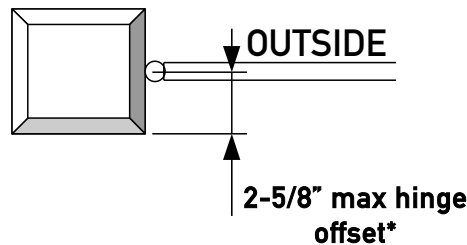

*** Maximum hinge offset does not apply to push to open applications**

WARNING

Please read and follow all instructions before installing and operating this product. Follow all local and federal building and electrical. BFT is not responsible for faults or damage cause by improper installation, application, or failure to comply with building codes.

6 POST BRACKET INSTALLATION

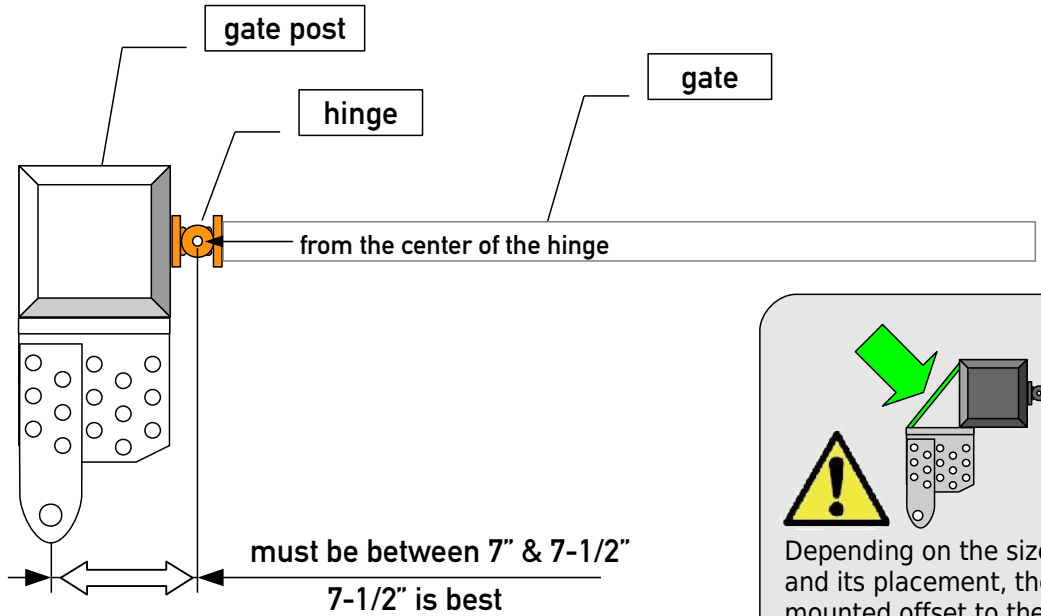

Depending on the size of the post, the type of hinge and its placement, the post bracket might have to be mounted offset to the gate post. This should require custom welding a brace or gusset (not supplied)

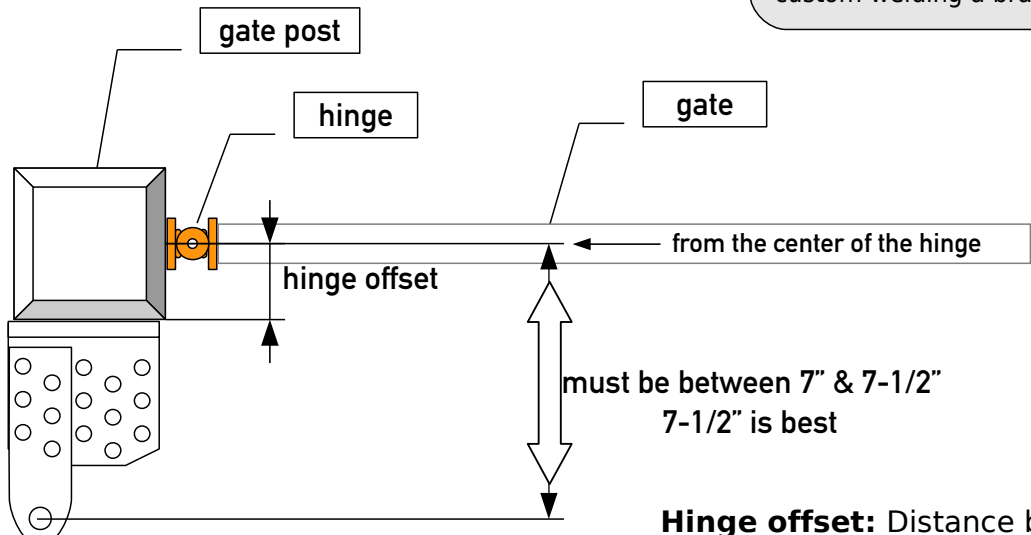

Hinge offset: Distance between the center-line of the hinge and the inside edge of the gate post

Post bracket length position	1	2	3	4
Hinge offset (1-1/8" min.)	up to 1-5/8"	up to 1-7/8"	up to 2-1/4"	up to 2-5/8"

The black dots represent the recommended bolt placement.

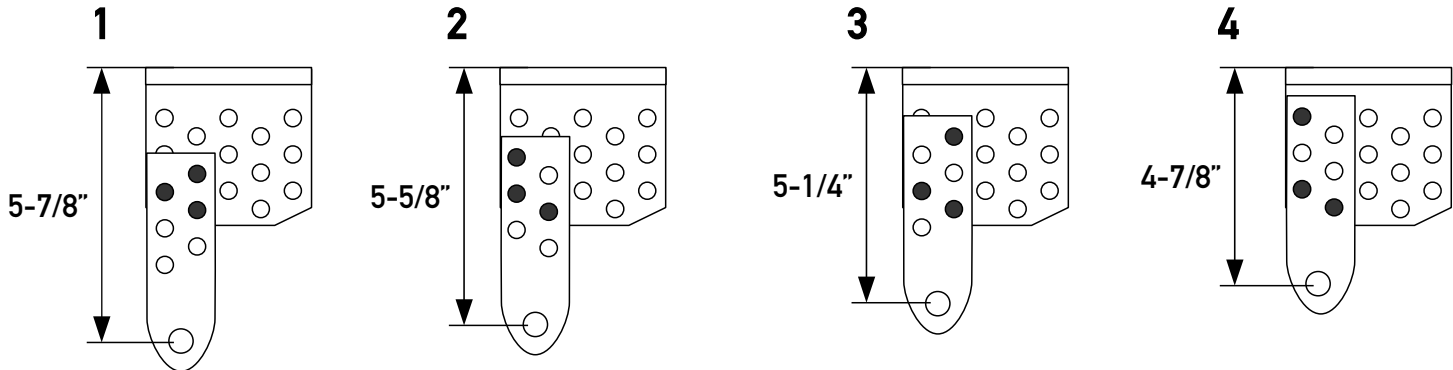

The suggested post bracket length positions are accurate only if the gate, on its fully closed position, is squared with the gate post

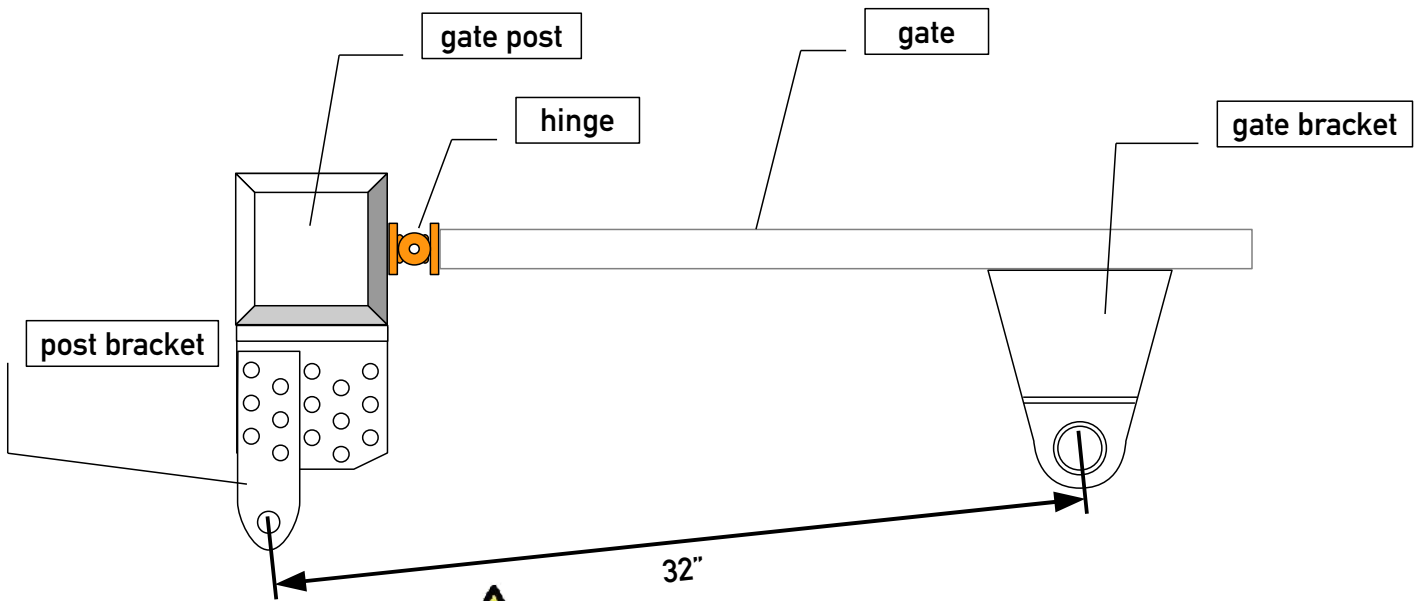

This measurement is taken with the gate fully closed

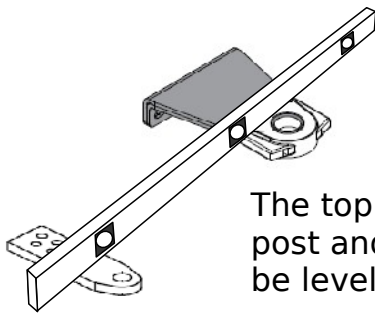

The top surface of both post and gate bracket must be leveled between the two

Install the magnet holder into the gate bracket

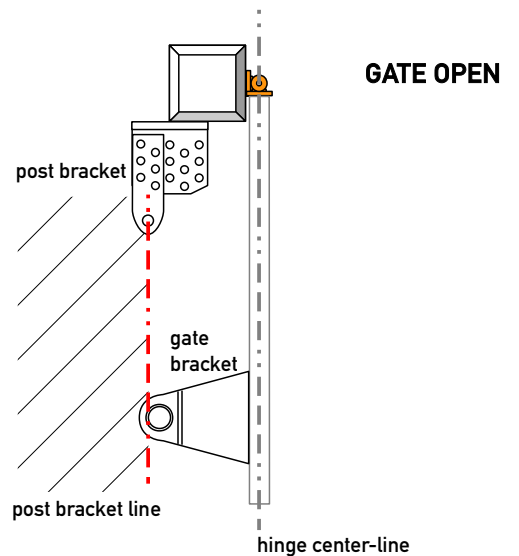
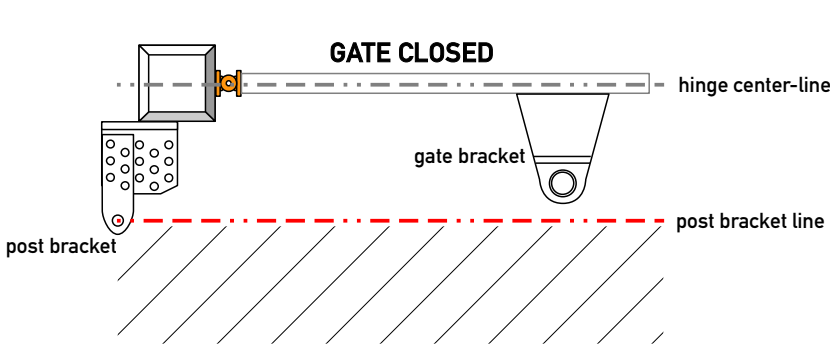
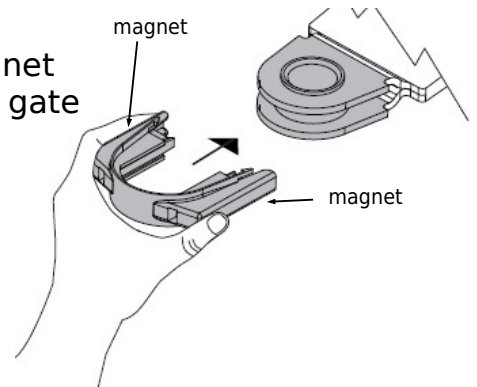

When the gate is on its fully open, or fully closed position, the distance from the center of the mounting hole of the gate bracket, to the hinge center-line, must be equal or less than that of the mounting hole on the post bracket to the hinge center-line. If you feel that you have followed the instructions on how to mount the brackets, and the distance of the hole of the gate bracket to the hinge center-line is greater than that of the post bracket, stop the installation process and contact technical support.

! WARNING: Push to open installations are not standard installations. The post bracket should require modifications and/or welding. The following illustrations do not represent the actual assembly of the post bracket. Its intentions is to illustrate the directions and dimensions of the bracket in relationship to the gate

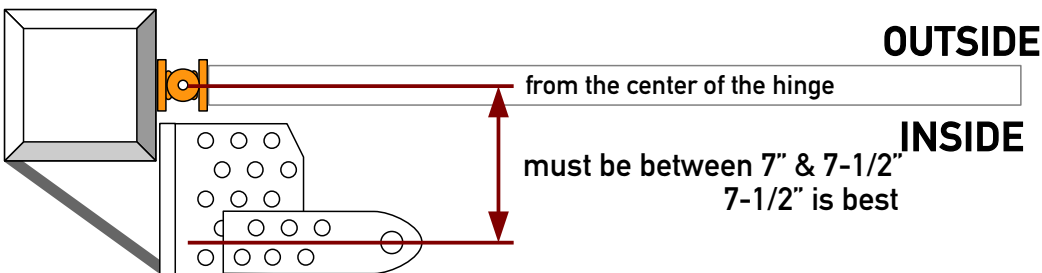
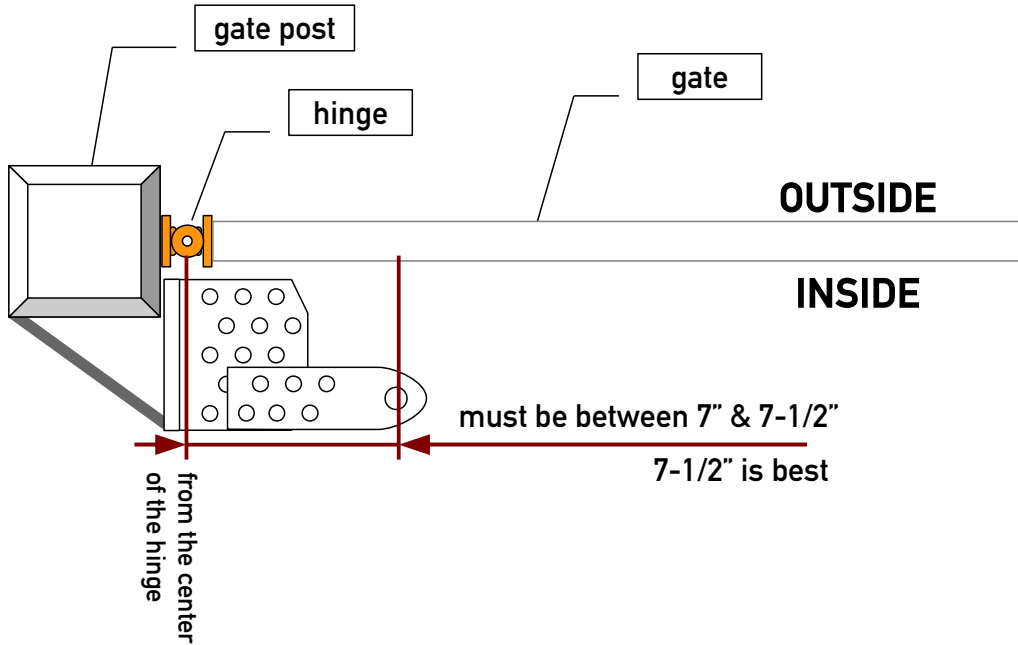

With the gate opened 90°, the distance between the mounting hole in both brackets must be 27 inches

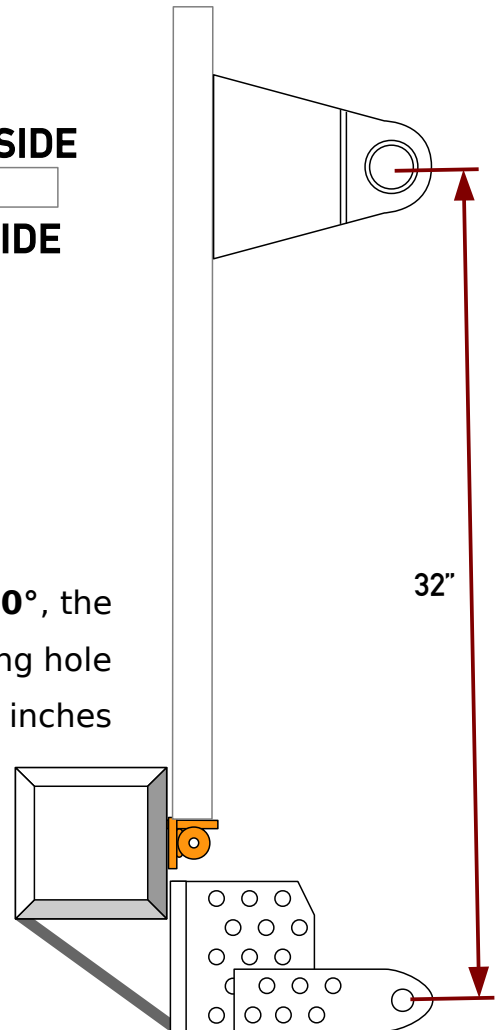

1. Strip about 1-1/2" off the outer jacket of the motor cable. Install the o-ring over the cable so that it is about 1/2" from the edge of the outer jacket

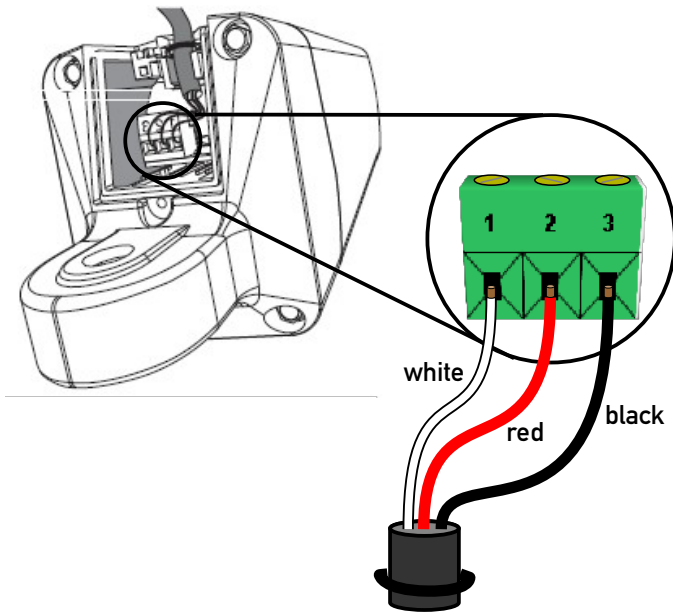
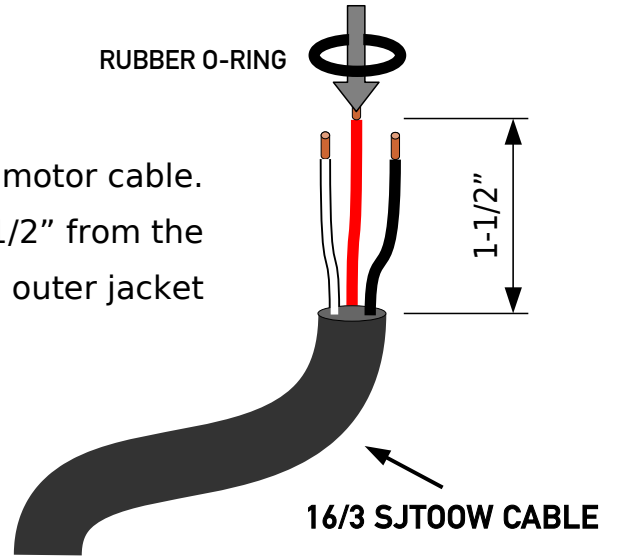

2. Turn the actuator upside down. Connect the white wire to terminal 1; the red wire to terminal 2; and the black wire to terminal 3

3. Install the back cover, making sure that the o-ring fits inside the groove to seal the operator from moisture

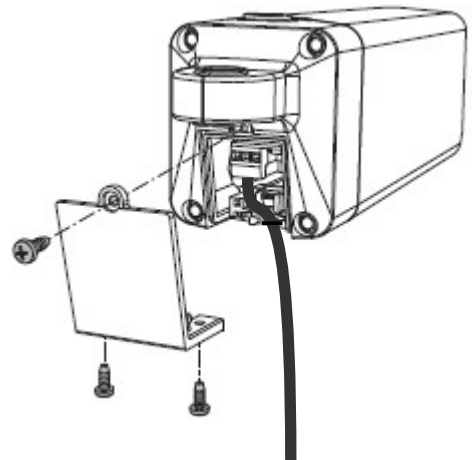

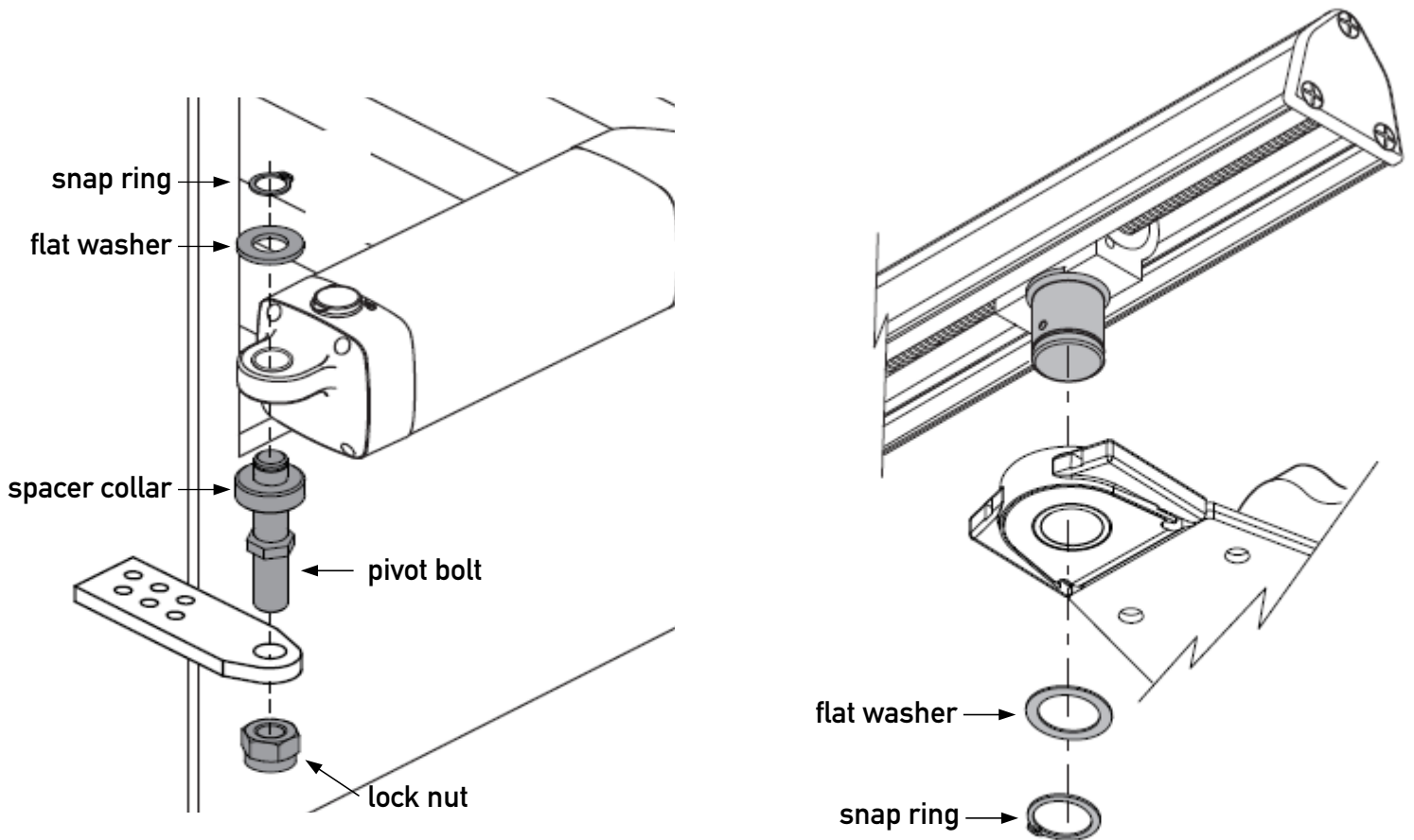

Attach the actuator to the mounting brackets as shown on the images above.



DO NOT INSTALL THE SNAP RINGS YET!!!

Place them in a secure location. Install the snap rings only once you have completely finalized the installation and all adjustments.



MAKE SURE THAT THE BODY OF THE ACTUATOR DOES NOT HIT THE MOUNTING BRACKET WHEN THE GATE IS FULLY CLOSED

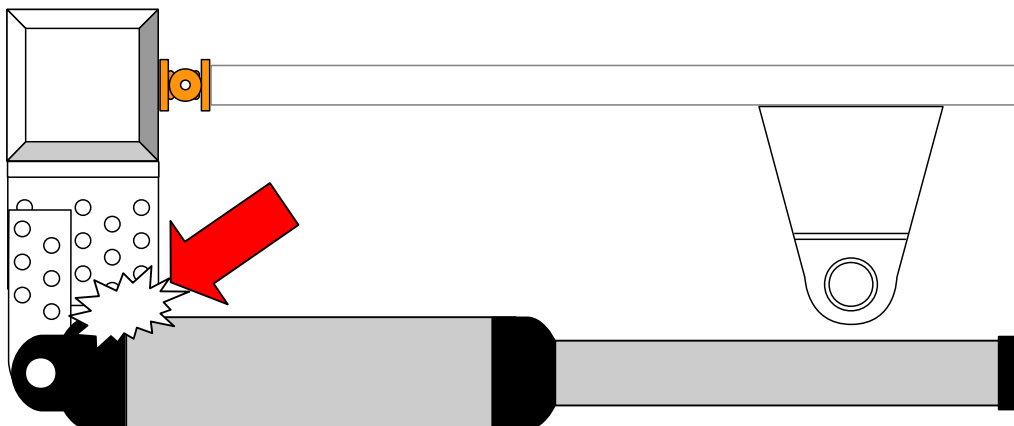

1) SET TO MANUAL OPERATION -

Disengage the drive gear by using the triangular key and turning clockwise.

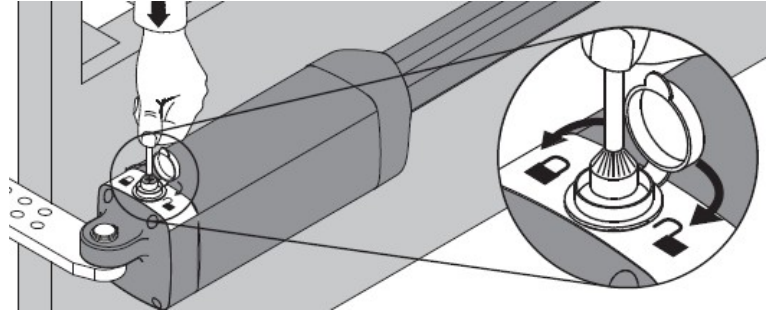

2) SET THE CLOSE LIMIT - Push the gate to its fully closed position. Remove the screw that holds the proximity sensor at the front end of the actuator. Slide it back so that the back end of the sensor housing is 3-1/2" from the center of the drive carriage and re-attach screw that secures sensor in place.

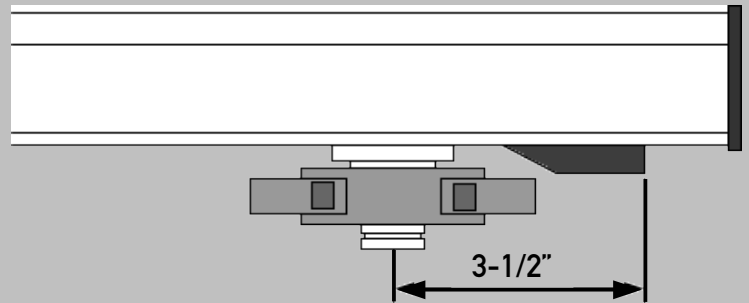
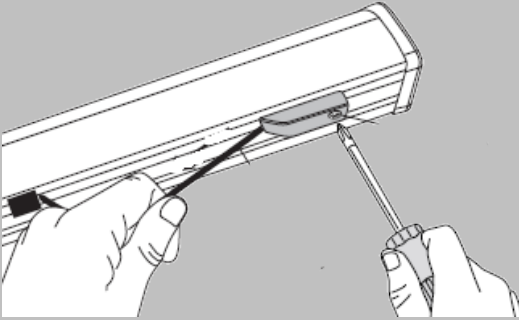

3) SET THE OPEN LIMIT - Push the gate to its fully open position. Remove the screw that holds the proximity sensor closest to the actuator body. Slide it forward so that the back end of the sensor housing is 3-1/2" from the center of the drive carriage and re-attach screw that secures sensor in place.

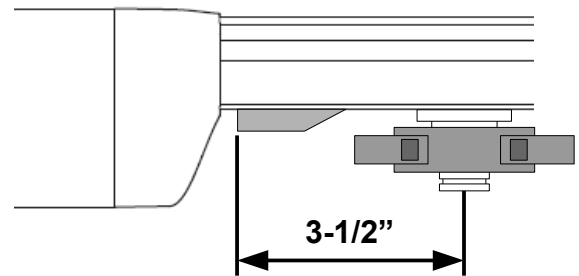

4) RE-ENGAGE THE MANUAL RELEASE - Use triangular key and turn counterclockwise to re-engage gears.

5) FINE-TUNING THE LIMITS - Once the actuator is connected to the controller, it must be powered and the limits might have to be fine-tuned by sliding them to the correct position.

12 INSTALLING THE STANDARD CONTROL BOX

Mounting the enclosure

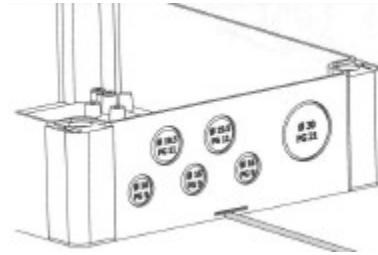
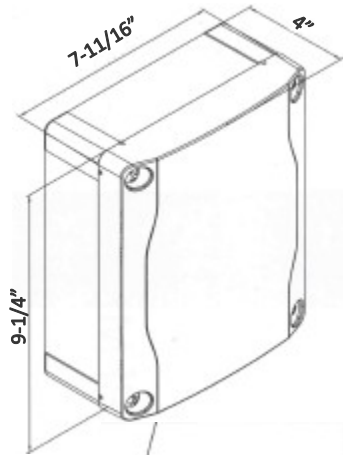

Several sizes knock-out punch conduit entries are provided

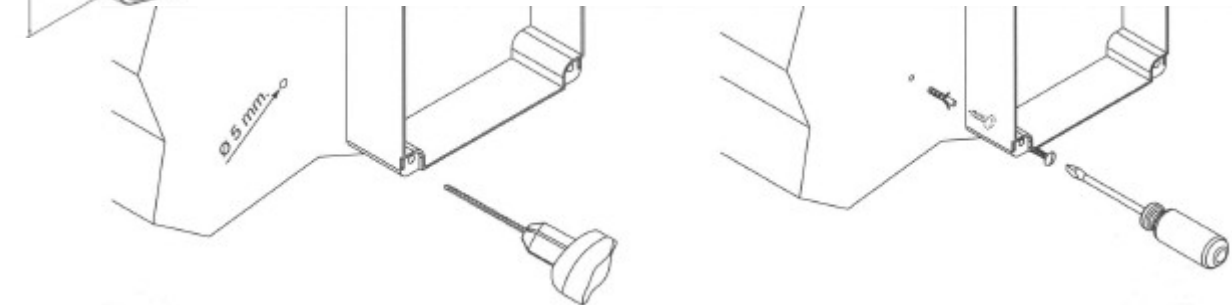

Using the lid screws port holes to fix the enclosure, ensures weatherproof protection of the electronic components.
Use plastic anchors for best results

Connecting power

Federal and local electrical codes must be followed.

120 Volts, single phase power is connected to the terminal strip on the lower left corner of the control board as shown.

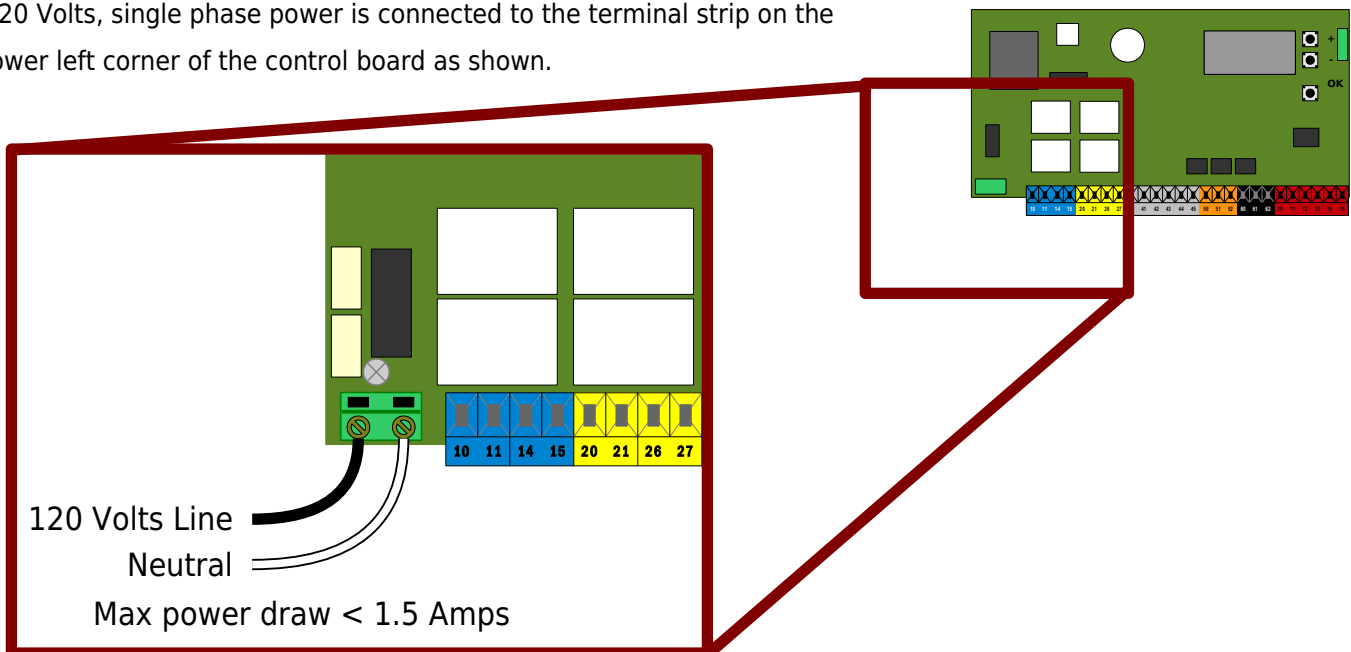

Mounting the enclosure

Use the mounting holes on the top and bottom flanges of the enclosure. Do not drill through the interior of the enclosure.

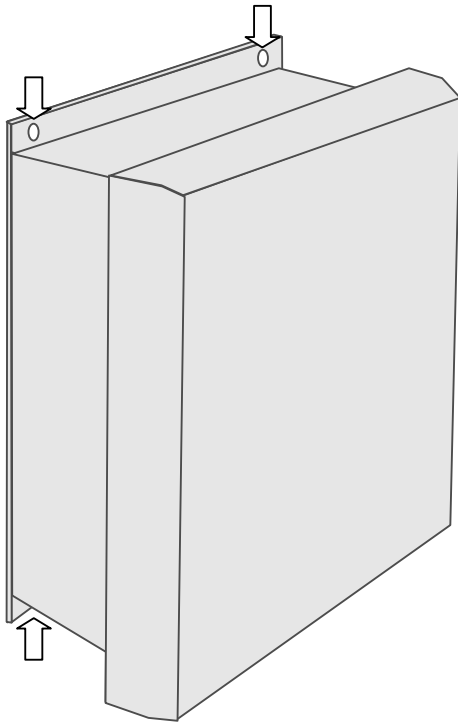

Do not perforate the top of the enclosure

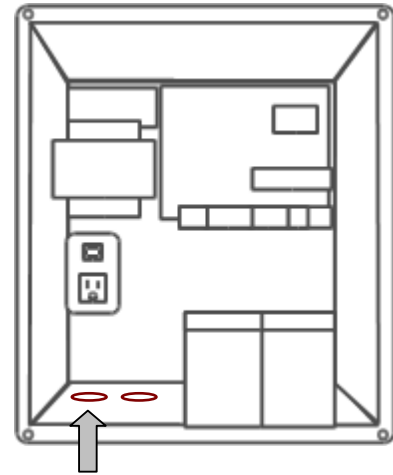

Bring all your wiring and/or conduits through the bottom of the enclosure. For best results, use a step drill bit to perforate the enclosure to the needed size opening

Connecting power

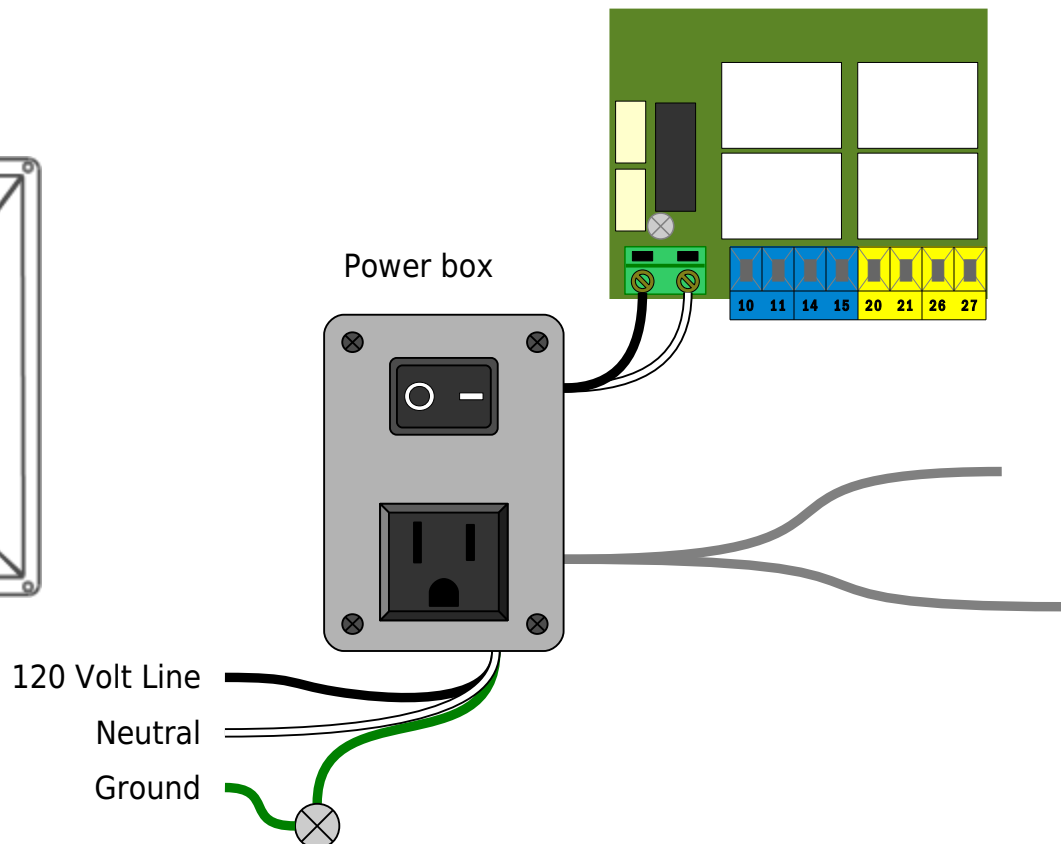
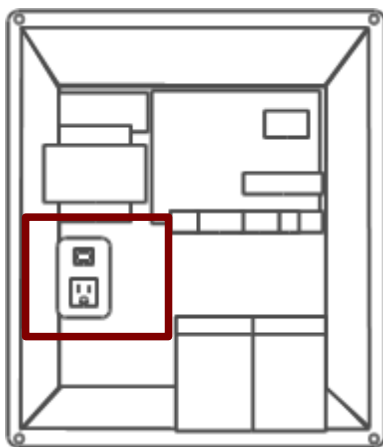

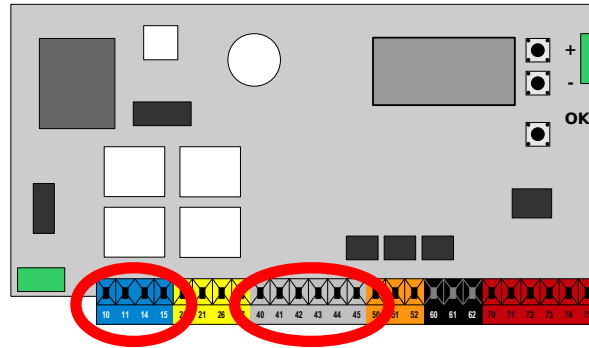

For single gate installations,
connect your motor wires to Motor 1
motor output (terminals 10 & 11),
and Motor 1 limit input (terminal 42).

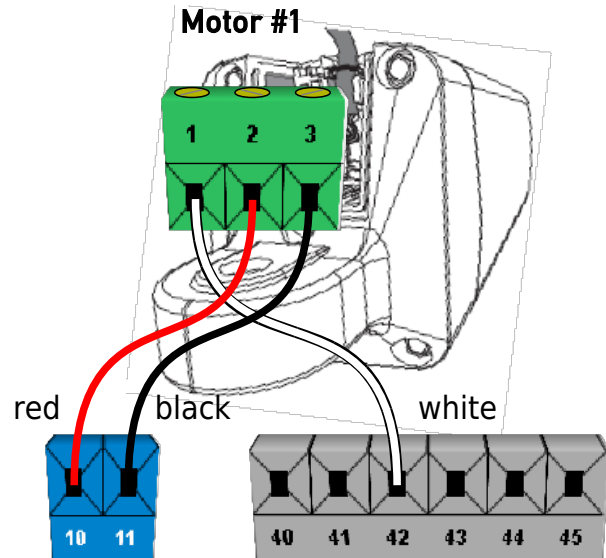

For dual gate installations,
connect your second motor wires to
Motor 2 motor output (terminals 14 &
15), and Motor 2 limit input (terminal
43).

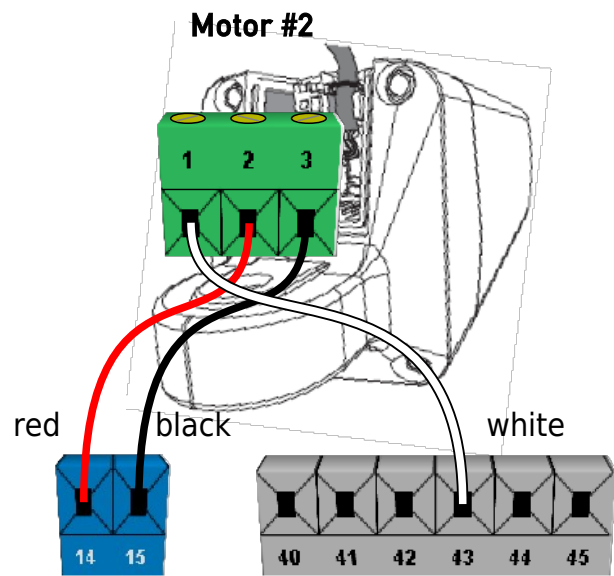

When installing a two leaf gate system, connect the motor wires from the gate that needs to open first to Motor 1 connections (10, 11 & 42), and connect the motor wires from the gate that needs to close first to Motor 2 connections (14, 15, & 43).

Quick Setup Menu flow chart

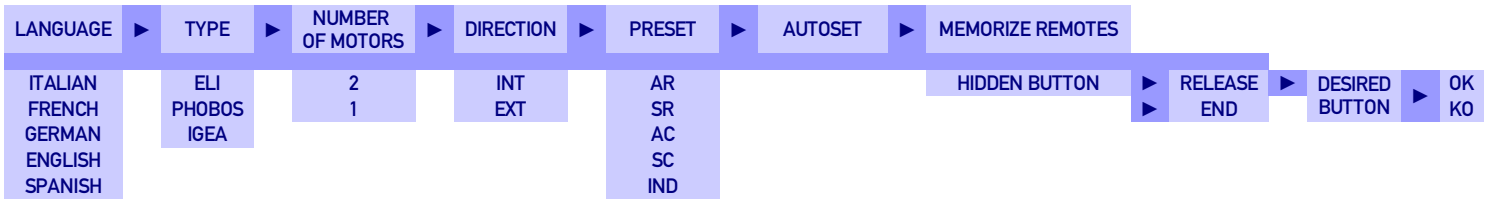

Quick Setup Menu navigation

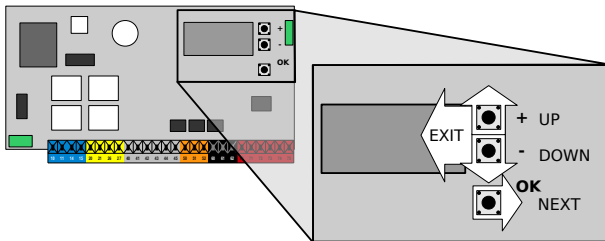

Pressing the **[+]** button scrolls **UP**

Pressing the **[-]** button scrolls **DOWN**

Pressing the **[OK]** button moves to the **NEXT** selection.

Pressing **[+]** and **[-]** at the same time **EXITS** the menu

STEP 1. Enter Quick Setup Menu

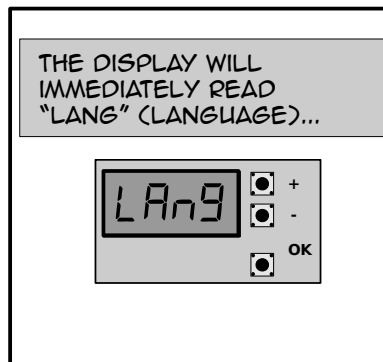
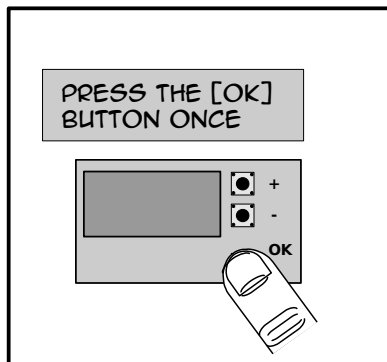

STEP 2. Set the menu language

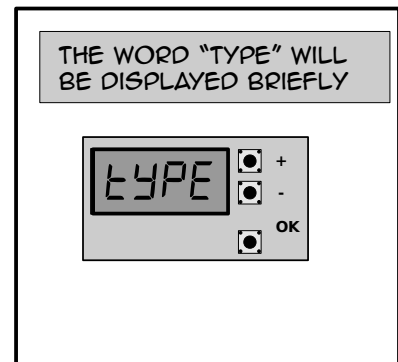
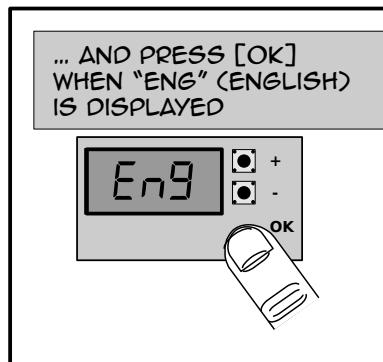
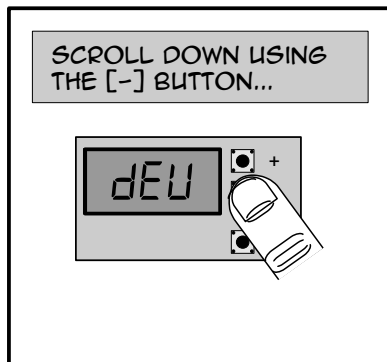

STEP 3. Select the type of operator

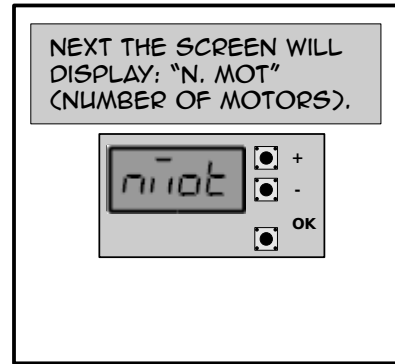
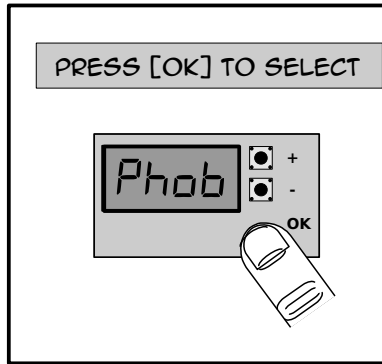
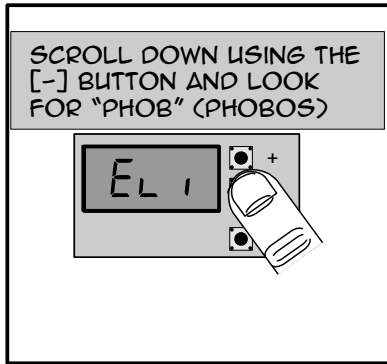

STEP 4. Set the number of motors connected

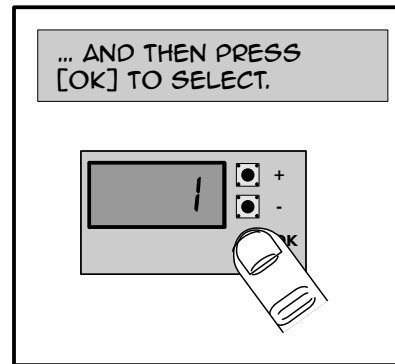
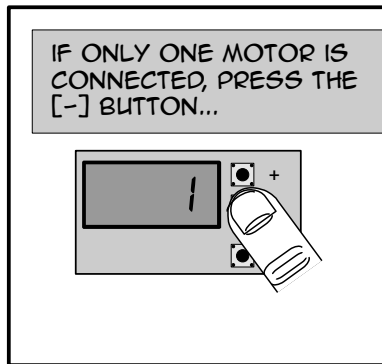
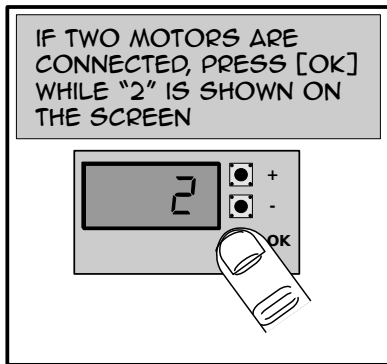

STEP 5. Set the opening direction

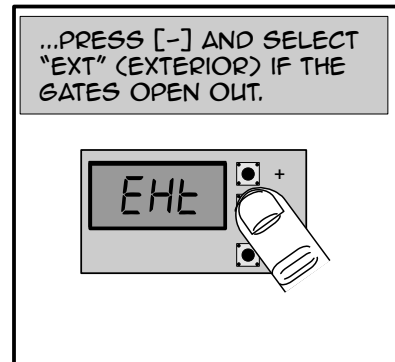
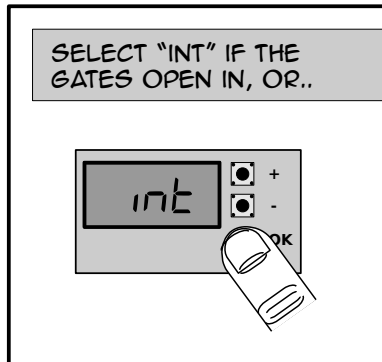
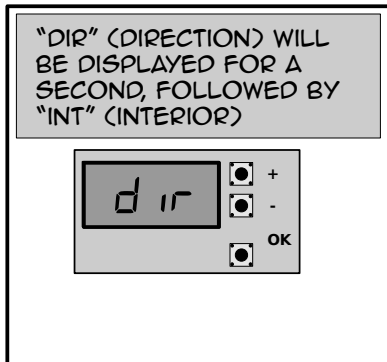

STEP 6. Set the desired preset

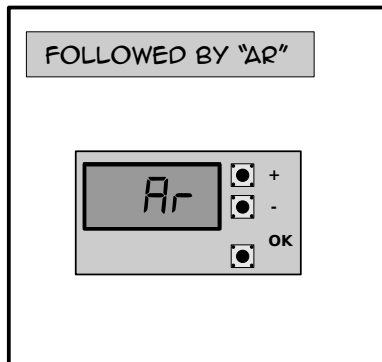
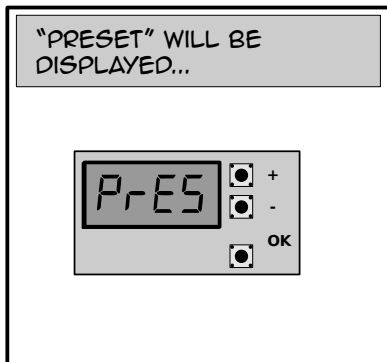

USE THE [-] BUTTON TO SCROLL DOWN AND THE [OK] BUTTON TO SELECT YOUR PREFERRED PRESET. PRESETS ARE EXPLAINED ON THE NEXT PAGE.

PRESETS

FEATURES	AR	SR	AC	SC	IND
	AUTOMATIC RESIDENTIAL	SEMI-AUTOMATIC RESIDENTIAL	AUTOMATIC COMMERCIAL	SEMI-AUTOMATIC COMMERCIAL	INDUSTRIAL
AUTOMATIC CLOSING TIMER	X		X		
PRE-ALARM			X	X	
UNINTERRUPTED OPEN CYCLE			X	X	
INSTANT REVERSE ON CLOSING	X		X		
HOLD TO RUN					X
QUICK REMOTE PROGRAMMING	X	X	X	X	

Automatic Closing Timer: Automatically closes the gate after gate fully opens and all safety devices are cleared.

Pre-Alarm: Energizes auxiliary relay with value set to “6”, for 3 seconds before energizing the motors.

Uninterrupted Open Cycle: Remote controls and START input is ignored during the open cycle.

Instant Reverse On Closing: A START command will instantly re-open gates during the close cycle. Otherwise, a START command first stops the gate requiring a second command to re-open.

Hold-To-Run: START command is disabled. Gate requires a constant “open “ or “close” command for it to run.

Quick Remote Programming: Allows adding remotes wirelessly using an existing working transmitter.

The “Residential” presets are not exclusive for residential applications the same way “Commercial” presets are not exclusive for commercial applications. They can both be used on any application depending on the needs and preferences of such installation. You can further customize your settings by using the Main Programming Menu.

STEP 7. Run the AUTOSET

AFTER SELECTING YOUR PRESET, THE SCREEN WILL DISPLAY "PROG" (PROGRAMMING) FOR A FEW SECONDS



THE SCREEN WILL THE DISPLAY "AUTOSET"

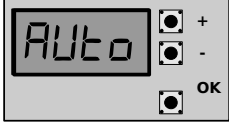

MAKE SURE THAT THE PATH OF THE GATE IS CLEAR OF TRAFFIC AND OBSTRUCTIONS.

BE AWARE THAT THE GATE WILL RUN AT FULL TORQUE DURING THE PROCESS. PRESS [OK] WHEN READY

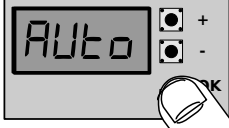

THE MOTOR(S) WILL RUN FULL OPEN AND CLOSE CYCLES MORE THAN ONCE...

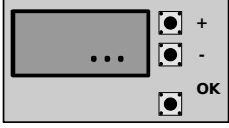

IF THE MOTOR(S) DON'T RUN AND/OR "KO" IS DISPLAYED, INSPECT THE GATE HARDWARE, MOTOR CONNECTIONS AND MANUAL RELEASE

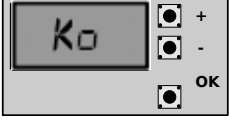

ONCE "OK" IS DISPLAYED, PRESS THE [OK] BUTTON TO CONTINUE

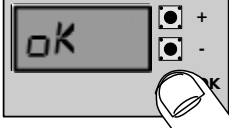

STEP 8. Program wireless transmitters

THE DISPLAY WILL READ "MEM. REMOTES" (MEMORIZE REMOTES)...



...IMMEDIATELY FOLLOWED BY "HIDDEN BUTTON". FIRMLY PRESS AND HOLD DOWN THE 2 TOP BUTTONS ON YOUR MITTO REMOTE

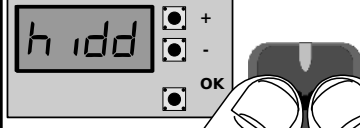

WHEN THE SCREEN READS "RELEASE", RELEASE THE TWO BUTTONS

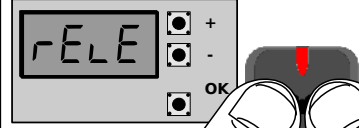

THE SCREEN WILL THEN READ "DESIRED BUTTON"

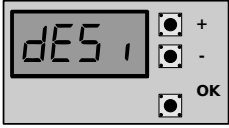

PRESS AND RELEASE THE BUTTON YOU WISH TO OPERATE THE GATE WITH



THE SCREEN DISPLAYS "HIDDEN BUTTON" AGAIN. YOU CAN REPEAT THE REMOTE LEARNING PROCESS OR PRESS [OK] TO END

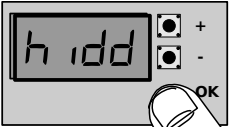

ACCESSORY POWER

24 volts accessories and peripherals can be powered from terminals 50 and 51

Terminal	Name	Description
50	- 24 V	Accessory power negative common
51	+ 24 V	Accessory power positive
52	+ 24 V-Safe	Positive power when gate is not closed

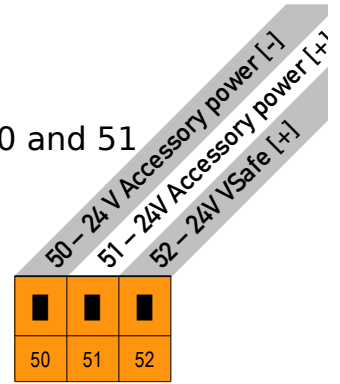

COMMAND INPUTS

The Thalia board provides two command inputs (IC1 and IC2).

Terminal	Name	Description	Default
60	COM	Command positive common	common
61	IC 1	Command Input 1	START
62	IC 2	Command Input 2	PED

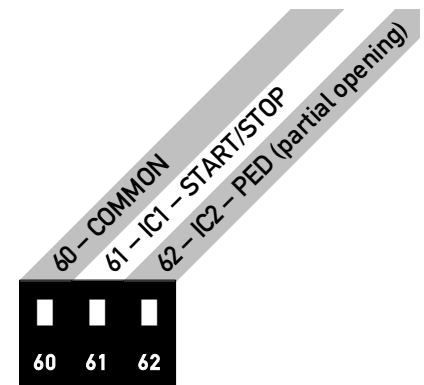

Command inputs 1 and 2 can be re-programmed to perform any of the following functions:

PROGRAMMING: LOGIC > IC # > 000 ~ 006

- 001 **START** Cycles between open, stop and close. Normally used with single push-buttons and radio receivers.
- 002 **OPEN** Open only command. Used with [open] buttons, free exit and/or open only devices.
- 003 **CLOSE** Close only. Used with [close] buttons and closing loop detectors
- 004 **PED** Pedestrian opening. Partially opens Motor 1 only.
- 005 **TIMER** Hold Open input.
- 006 **TIMER PED** Holds partially open motor 1

Please refer to LOGIC programming for IC 1 and IC 2 re-programming

EXAMPLE: OPEN ONLY DEVICES WIRING

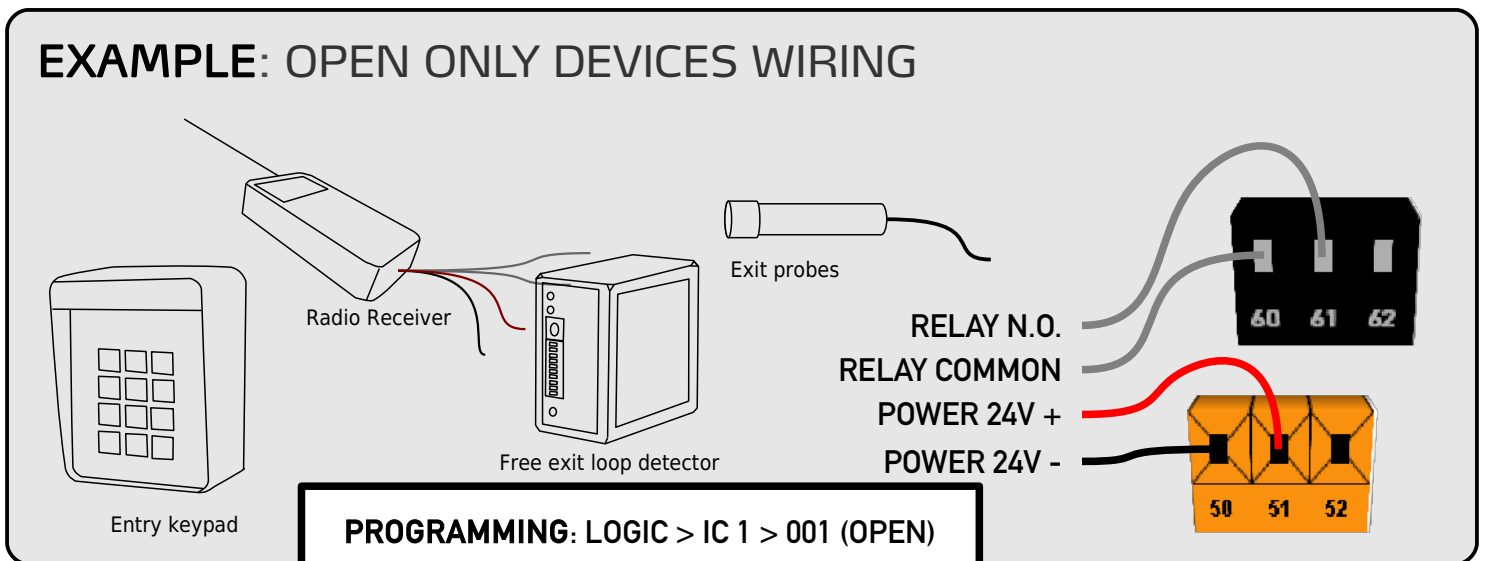

PROGRAMMING: LOGIC > IC 1 > 001 (OPEN)

The Thalia board provides one **STOP** command input, and two programmable obstruction sensing device inputs, **SAFE1** and **SAFE2**. All 3 safety inputs are **N.C. (normally closed) contacts**. Both SAFE 1 and 2 have a device supervision circuit labeled **FAULT**. Fault inputs, when enabled, are all normally open.

Below is a table with the terminal numbers and its corresponding functions and default values.

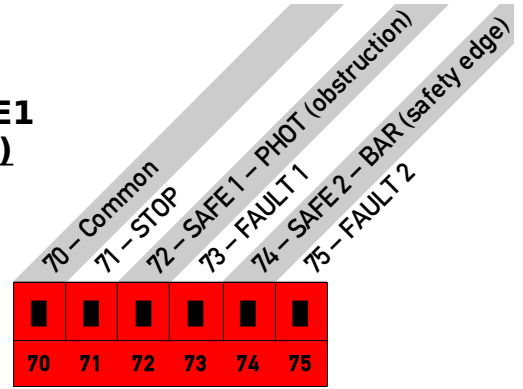

Terminal	Name	Description	Default	Notes
70	COM	Safety positive common	common	
71	STOP	Stop command.	STOP	Overrides all other commands
72	SAFE 1	Safety input #1.	PHOT	Stops operators during opening, reverses on closing
73	FAULT 1	Supervisory circuit for SAFE 1	FAULT	Requires opposite relay state from SAFE 1
74	SAFE 2	Safety input #2.	BAR	Input for safety edges
75	FAULT 2	Supervisory circuit for SAFE 2	FAULT	Requires opposite relay state from SAFE 2

Both **SAFE1** and **SAFE2** can be programmed to perform any of the following functions under the **LOGIC** sub-menu:

VALUE	FUNCTION	DESCRIPTION
000	PHOT	System reacts to the input in both opening (stops) and closing (reverses) cycles
001	PHOT TEST	Same as above. Requires the device to be supervised (FAULT active)
002	PHOT OP	System reacts to the input only during the opening cycle (stops)
003	PHOT OP TEST	Same as above. Requires the device to be supervised (FAULT active)
004	PHOT CL	System reacts to the input only during the closing cycle (reverses)
005	PHOT CL TEST	Same as above. Requires the device to be supervised (FAULT active)
006	BAR	Safety edge input. It reacts in both opening and closing. Stops and partially reverses.
007	BAR TEST	Same as above. Requires the device to be supervised (FAULT active)
008	BAR 8K2	Safety edge input with EOL resistor as supervision method.

EXAMPLE: SAFETY LOOP DETECTOR OR SAFETY PHOTO BEAM SENSOR WIRING

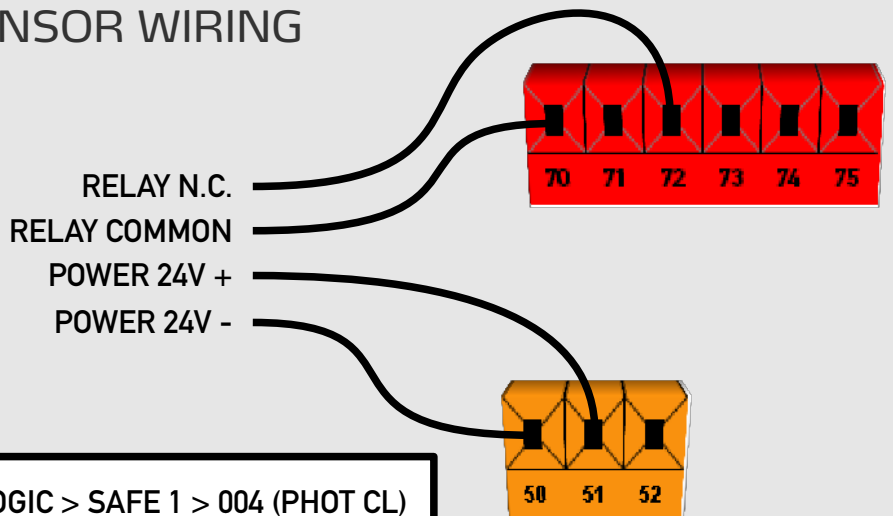
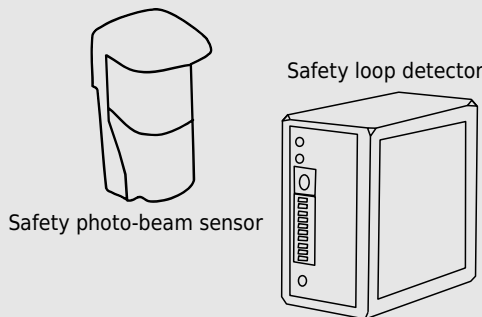

PROGRAMMING: LOGIC > SAFE 1 > 004 (PHOT CL)

The Thalia board has two auxiliary outputs. The first (20 & 21), is a 24 volt, courtesy light output that will activate upon activation of the gate, and will remain on for 90 seconds after the gate has closed.

The second output labeled **AUX 3** (26 & 27), is defaulted as second channel radio receiver output, but can be re-programmed to perform any of the following functions under the **LOGIC** sub-menu:

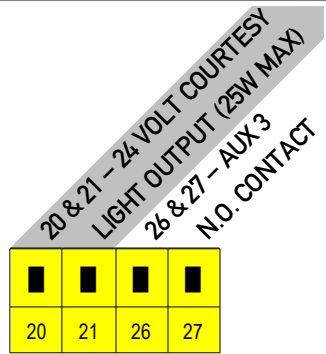

AUX3 max contact rating: 24v, 3W (transistor output)

VALUE	FUNCTION
0	2ND CHANNEL RECEIVER OUTPUT. Output active when transmitter activates the 2nd channel
1	GATE OPEN LIGHT. Output active when gate is not closed. flashes while closing
2	COURTESY LIGHT. Output active during and for 90 seconds after operation.
3	GATE NOT CLOSED. Output active until close limit is reached
4	START OF CYCLE. Output active for 1 second at the beginning of each cycle
5	GATE OPEN ALARM. Output active if gate is held open for more than double the timer to close time
6	GATE RUNNING. Output active while motors are powered
7	SOLENOID LOCK. Output active for 2 second at the beginning of open cycle
8	MAGNETIC LOCK. Output active when gate is closed

EXAMPLE: SHADOW LOOP DETECTOR WIRING USING AUXILIARY OUTPUT

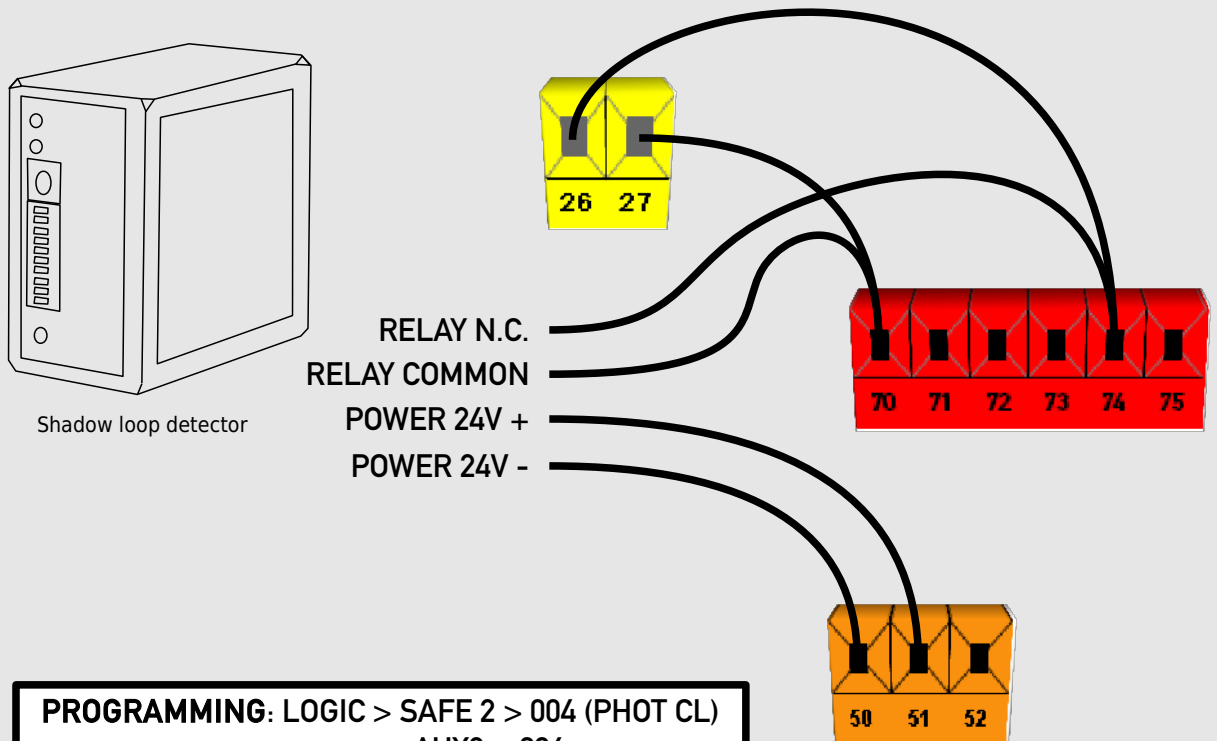

Main Programming Menu navigation

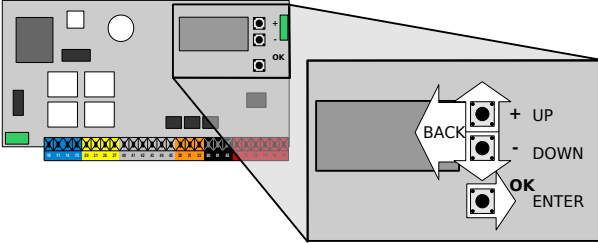

Pressing the **[+]** button scrolls **up** or **increases** value

Pressing the **[-]** button scrolls **down** or decreases value

Pressing the **[OK]** button serves as **ENTER**

Pressing **[+]** and **[-]** at the same time serves as **BACK**

(Parameters) PARAM	Sub-menu. All numerical value are set in this area (times, forces, & speeds).
LOGIC	Sub-menu. All features and functions are selected in this area .
RADIO	Sub-menu. Built-in receiver programming (remote controls and wireless devices).
DEFAULT	Restores all factory settings. Has no effect on RADIO programming.
LANGUAGE	Selection of menu language.
AUTOSET	Motor learn feature.
STAT	Provides firmware and memory information.
PASSWORD	Password setting for wireless programmer.

MAIN	SELECTION	DESCRIPTION	DEFAULT	RANGE	
PARAM >	OPEN DELAY TIME	Motor 2 opening delay in seconds	1	0-10	
	CLS DELAY TIME	Motor 1 closing delay in seconds	1	0-10	
	TCA	Auto-close time adjustment in seconds	10	1-180	
	TRF. LGHT. CLR. T	Traffic zone clear time adjustment in seconds	40	1-180	
	OP. DIST. SLOWD	Slowdown starting distance from end of open travel expressed in percentage	10	0-50	
	CL. DIST. SLOWD	Slowdown starting distance from end of close travel expressed in percentage	10	0-50	
	DIST. DECEL	Slowdown starting distance from end of open and close travel expressed in percentage	15	0-50	
	OP. FORCE	Percentage of opening force exerted over the AUTOSET value before obstruction is sensed	50	1-99	
	CLS. FORCE	Percentage of closing force exerted over the AUTOSET value before obstruction is sensed	50	1-99	
	OP SPEED	Motor opening speed expressed in percentage	99	15-99	
	CL SPEED	Motor closing speed expressed in percentage	99	15-99	
SLOW SPEED	Slowdown speed expressed in percentage from maximum speed.	25	15-99		
LOGIC >	MOTOR TYPE	1=Eli 250; 2=Phobos BT, 3=Igea BT	0	0-3	
	TCA	Timer to Close Automatically. 0=OFF / 1=ON	0	0-1	
	FAST CLS.	Closes when sensors are cleared. 0=OFF / 1=ON	0	0-1	
	STEP-BY-STEP MOVEMENT *	Determines how the system reacts when a START command is received during operation	0	0-2	
	PRE-ALARM	Gate running output (AUX value=6) closes 3 sec. before gate movement. 0=OFF / 1=ON	0	0-1	
	HOLD-TO-RUN	Requires continuous OPEN or CLOSE command input for gate to operate. 0=OFF / 1=ON	0	0-2	
	IBL OPEN	Ignores START input during the opening cycle. 0=OFF / 1=ON	0	0-1	
	IBL TCA	Ignores the START input while counting down for automatic closing. 0=OFF / 1=ON	0	0-1	
	IBL CLOSE	Ignores the START input during the closing cycle. 0=OFF / 1=ON	0	0-1	
	RAM BLOW C. OP	Pushes gate against physical stop before opening	0	0-1	
	RAM BLOW C. CL	Pushes gate against physical stop before closing	0	0-1	
	BLOC PERSIST	Hourly push against physical stop	0	0-1	
	PRESS SWC	Pushes gate against physical stop for .5 seconds after close limit has been reached.	0	0-1	
	ICE	Continuous force learning on every operation.	0	0-1	
	1 MOT. ON	Single Motor operation. 0= (2)motors; 1=(1)motor.	0	0-1	
	OPEN IN OTHER DIRECT.	0 = Pull to open; 1 = Push to open	0	0-1	
	see page 20 {	SAFE 1 *	Configuration of safety input terminal 72. Defaulted as Phot (Obstruction)	0	0-8
		SAFE 2 *	Configuration of safety input terminal 74. Defaulted as Bar (Safety Edge)	6	0-8
	see page 19 {	IC 1 *	Configuration of command input terminal 61. Defaulted as Start E	0	0-6
		IC 2 *	Configuration of command input terminal 62. Defaulted as Ped (Partial open)	4	0-6
	see page 21 {	AUX 3 *	Configuration of auxiliary output terminals 26 & 27. Defaulted as 2 nd channel contacts.	0	0-8
		FIXED CODE	Rolling code defeat. 0 = rolling code; 1 = fixed code	0	0-1
		RADIO PROG	Quick remote programming. 0 = disabled; 1 = enabled	1	0-1
		SERIAL MODE	0 = Slave unit; 1 = Master unit	0	0-1
		ADDRESS	Unit's network identification number.	0	0-127
		EXPI 1 *	Configuration of Expansion board input 1. Defaulted as Start command.	1	0-14
		EXPI 2 *	Configuration of Expansion board input 2. Defaulted as Start command.	0	0-10
EXPO 1 *		Configuration of Expansion board output 1. Defaulted as Traffic light control..	9	0-9	
EXPO 2 *		Configuration of Expansion board output 2. Defaulted as Traffic light control..	9	0-9	
TRAFFIC LIGHT PREFLASHING		Red light flashes for 3 sec. at every start. 0 = Off; 1 = On	0	0-1	
TRAFFIC LIGHT RED LAMP ALWAYS ON		Red light remains on when gate is closed. 0 = Off; 1 = On	0	0-1	
RADIO >		ADD START	Learns transmitter button as START command		
		ADD 2CH	Learns transmitter button as 2 nd channel		
	ERASE 64	Erase complete memory			
	COD RX	Show receiver ID Code			
	WK	W LINK.			
DEFAULT	Restores board to factory settings. No effect on RADIO				
LANGUAGE >	ITA	Italian			
	FRA	French			
	DEU	German			
	ENG	English			
	ESP	Spanish			
AUTOSET	Operates motor(s) several times and automatically adjust its FORCE settings				
L. SWADJ	Limit of travel adjustment. Only available with type 4 and 5 motors				
STAT >	VERS	Displays board firmware version.			
	N. CYCLES	Displays number of hundreds of cycles (001=100; 010=1000; 100=10,000)			
	N. REMOTES	Displays the number of remotes in memory.			
	ERR	Displays the last 30 board errors in descending order.			
PASSWORD	Password setting for wireless programmer				

MAGNETIC LOCK WIRING USING BFT 24V AC/DC RELAY

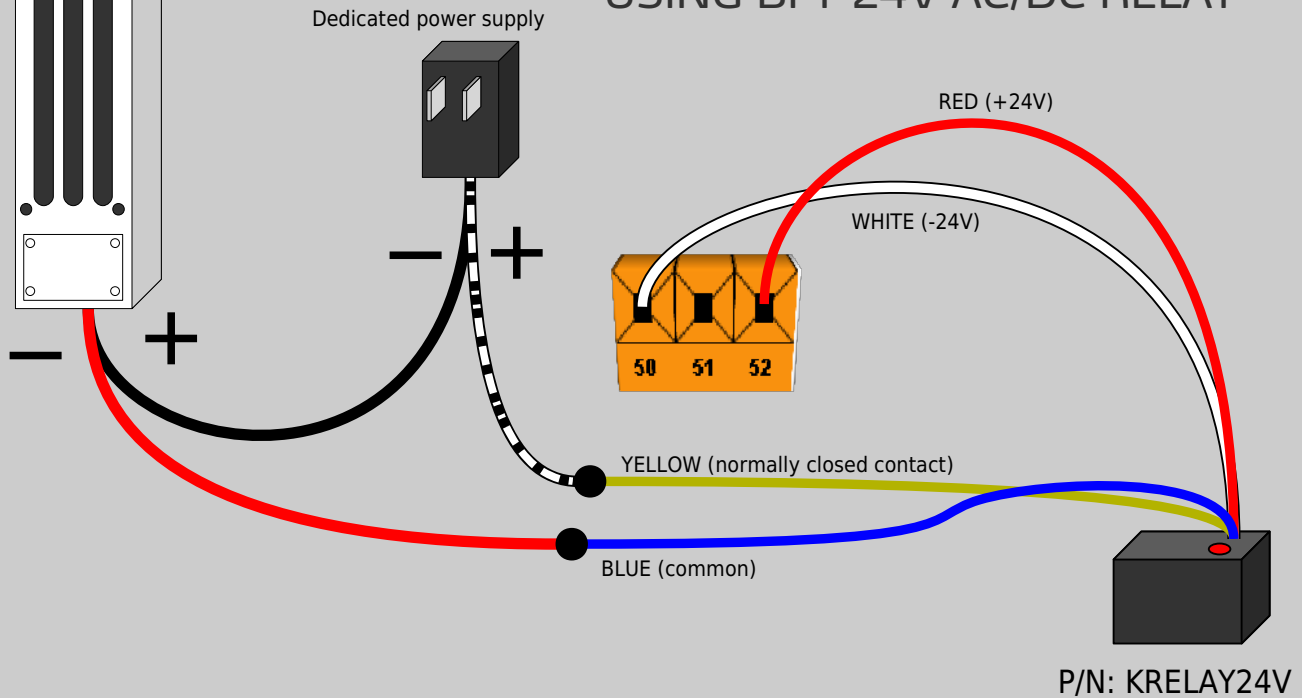

BATTERY BACKUP WIRING DIAGRAM

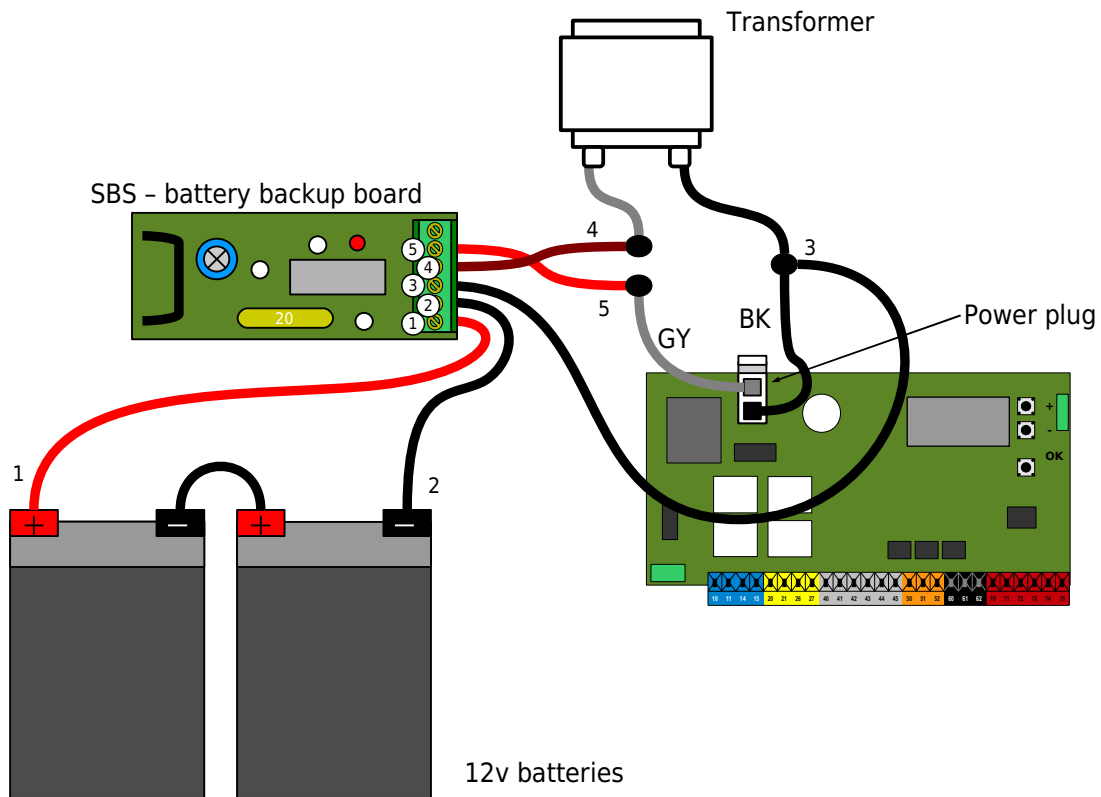

DISCONNECT ALL POWER INCLUDING BATTERIES IF APPLICABLE BEFORE PERFORMING ANY MAINTENANCE OR REPAIR TO THE ACTUATORS

MAINTENANCE - Inspect the screw-drive gears for lubrication, debris and cleanness at least once a year. For actuators installed in areas where dirt and dust are a concern, maintenance should be done at shorter intervals. Keep the screw-drive lubricated using **BFT** grease part number: **I101115**. Do not apply grease if gears are dirty. If necessary, clean with degreaser before applying new grease.

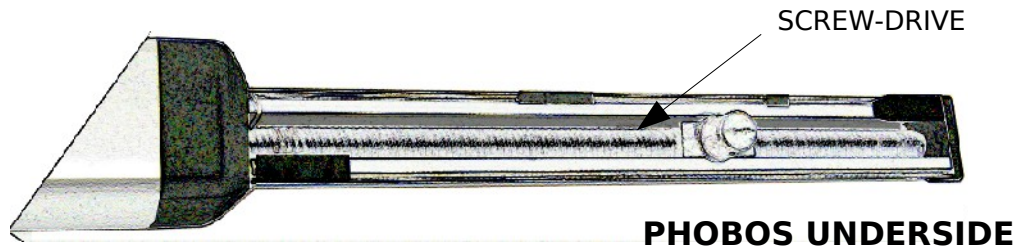

REFER TO THE CONTROLLER INSTALLATION MANUAL FOR TROUBLESHOOTING

MANUAL OPERATION - Disengage the drive gear by using the triangular key and turning clockwise. Re-engage the gears by turning the key counterclockwise.

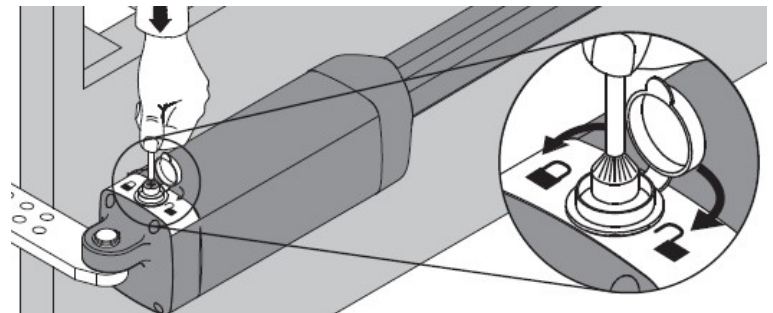

COMMON ERROR CODES

ERROR	DESCRIPTION	ERROR	DESCRIPTION
ER20	MOTOR 2 IMPROPER ENCODER MOVEMENT DETECTED	ER35	MOTOR 1 OBSTACLE DETECTION DURING OPENING
ER22	MOTOR 2 OPPOSITE MOVEMENT	ER36	MOTOR 1 OBSTACLE DETECTION DURING CLOSING
ER25	MOTOR 1 IMPROPER ENCODER MOVEMENT DETECTED	ER37	MOTOR 1 OBSTACLE DETECTION DURING OPENING SLOWDOWN
ER27	MOTOR 1 OPPOSITE MOVEMENT	ER38	MOTOR 1 OBSTACLE DETECTION DURING CLOSING SLOWDOWN
ER30	MOTOR 2 OBSTACLE DETECTION DURING OPENING	ER40	THERMAL OVERLOAD
ER31	MOTOR 2 OBSTACLE DETECTION DURING CLOSING	ER61	OPERATING ON BATTERY POWER
ER32	MOTOR 2 OBSTACLE DETECTION DURING OPENING SLOWDOWN	ERSW	ERROR SETTING LIMITS
ER33	MOTOR 2 OBSTACLE DETECTION DURING CLOSING SLOWDOWN	ERF9	LOCK OUTPUT OVERLOAD

Thalia control board

Includes enclosure and transformer

P/N: D113745 00001

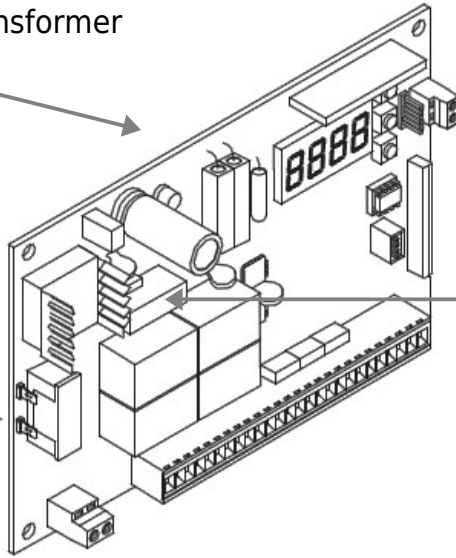

Primary fuse

2.5 Amps, slow-blow
5mm x 20mm

Secondary fuse

3.15 Amps, slow-blow
5mm x 20mm

Manual release key

P/N: D610180



⚠ Phobos motor board

P/N: D111709 00001

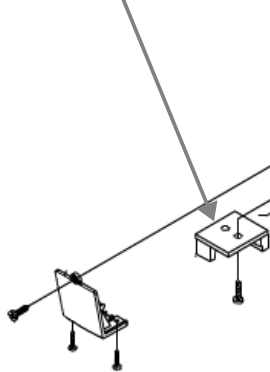

End Cap

P/N: I105800

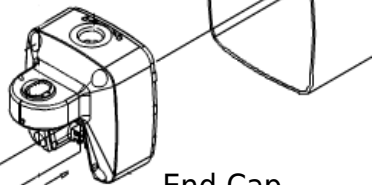

Trolley assembly

P/N: I099827

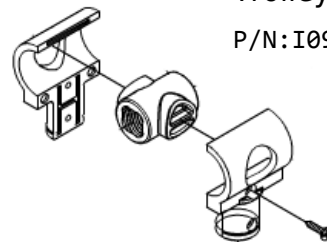

Gate Bracket & Magnet Holder

P/N: N999427

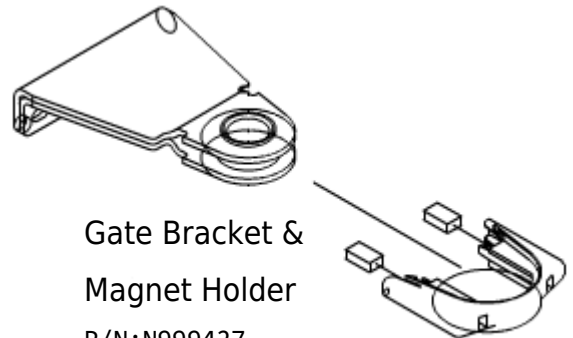

⚠ Limit sensor assembly

includes 4 sensors (for 2 motors)

P/N: I105804

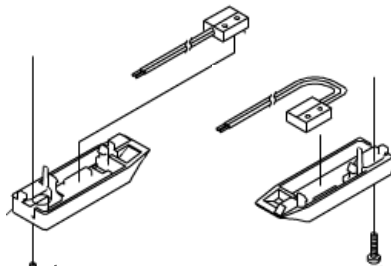

It is highly recommended to, when necessary, replace both the limit sensors and motor board together.



THALIA P LE-B
 P/N: KTHALIA12U
 Large 12" x 14" control board enclosure. Includes battery backup with (2) 12V, 9 Ah batteries. The Thalia "P" version features additional programmable inputs and outputs for greater integration capabilities. Dedicated external lock output eliminates the need for additional power supplies or relays to drive your magnetic or solenoid lock.



ECOSOL THALIA
 Solar powered system. Includes 10W 24V solar panel (30W panel optional), (2) 9Ah batteries, Ecosol solar interface board, (2) remotes. 100 cycles per day. Residential use only.



T-BOX
 P/N: P121019
 10 channel wireless keypad. With memory for up to 99 codes, a single keypad can control up to 10 devices in a single location.



CLONIX 2E
 P/N: D113674 00001
 Two channel external, weatherproof receiver. With memory for 128 or 2048 transmitters (optional), it is capable of controlling two independent gates or doors. Programmable relays can also be used as "hold open" feature"



AEL 433
 P/N: D113632
 External antenna tuned for 433Mhz, doubles the standard range of the remote controls.



MITTO
 P/N: D111904 (2 buttons)
 P/N: D111906 (4 buttons)
 Extended range (200 ft. under optimal conditions) two button remote control. Can be used to operate two separate gates or, combined with the Clonix 2E, as open and hold open control. Also available with four buttons.



POLARIZED IR SENSOR
 P/N: KIRPOLAPHOT001
 30 ft. range. The polarized lens improves performance of the sensor under rainy, foggy or damp conditions. 2 axis adjustment for ease of installation. Includes reflector hood. 12 ~250 v ac/dc



SEK
 P/N: P121017
 Vandal resistant key switch. Can send two individual commands (contact closures) or operate two separate gates or doors.

AT A GLANCE QUICK REFERENCE

Phobos N L BT Geometry

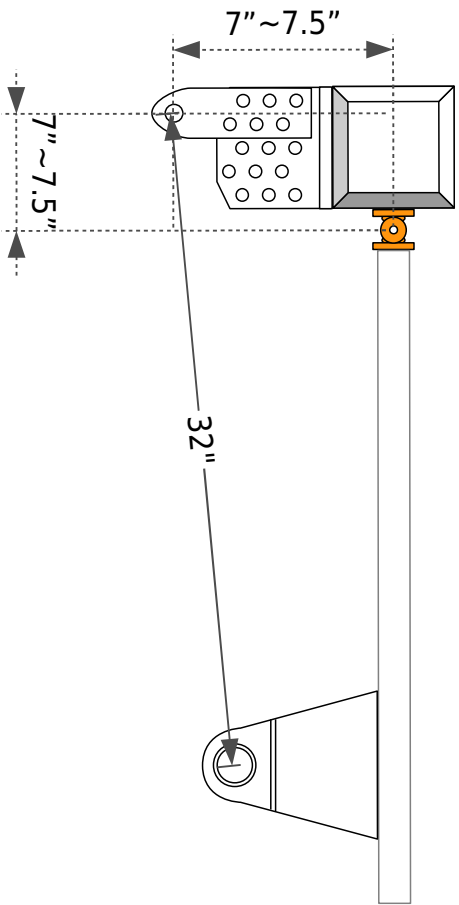

Programming

Quick Setup Menu: Press **OK** once

LANGUAGE	TYPE	NUMBER OF MOTORS	DIRECTION	PRESET	AUTOSET	MEMORIZE REMOTES	HIDDEN BUTTON	RELEASE	END	DESIRED	OK
ITALIAN FRENCH GERMAN ENGLISH SPANISH	ELI PHOBOS IGEA	1 2	NT EXT	AR SR AC SC IND							

Main Programming Menu: Press **OK** twice **RAPIDLY**

(Parameters) PARAM	Sub-menu. All numerical value are set in this area (times, forces, & speeds).
LOGIC	Sub-menu. All features and functions are selected in this area.
RADIO	Sub-menu. Built-in receiver programming (remote controls and wireless devices).
DEFAULT	Restores all factory settings. Has no effect on RADIO programming.
LANGUAGE	Selection of menu language.
AUTOSET	Motor learn feature.
STAT	Provides firmware and memory information.
PASSWORD	Password setting for wireless programmer.

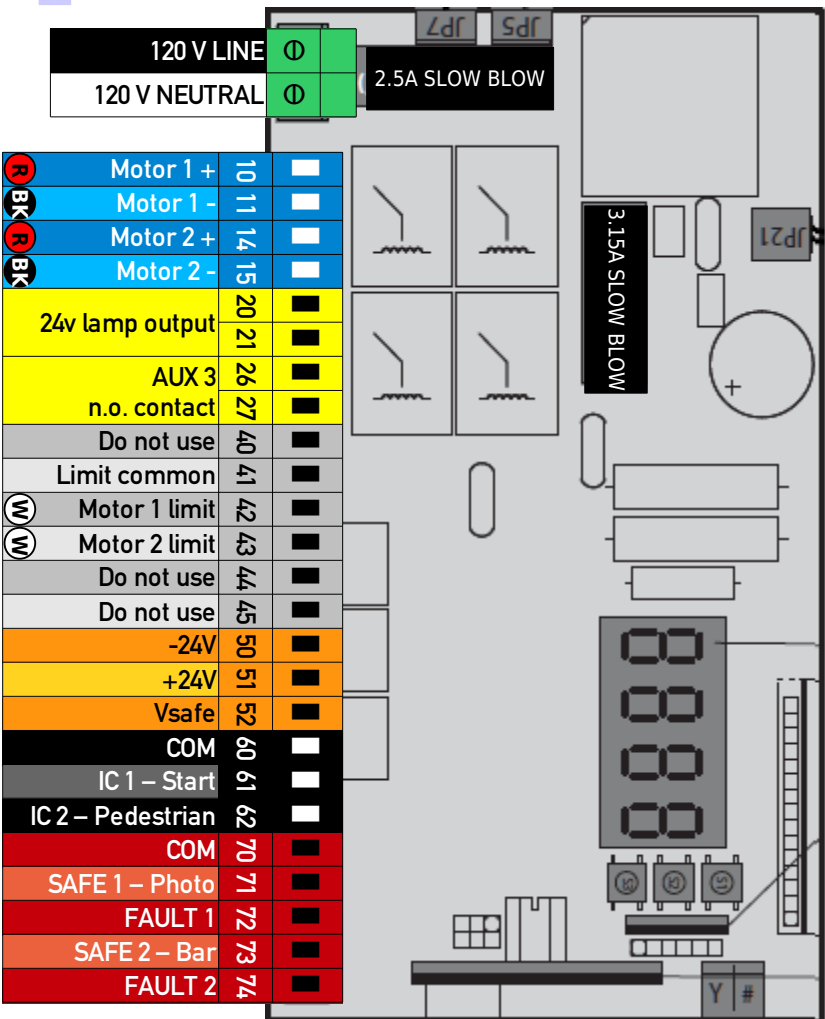

IC Values (terminals 61 & 62)

LOGIC > IC# > 000 ~ 006

001	START	Cycles between open, stop and close. Normally used with single push-buttons and radio receiver
002	OPEN	Open only command. Used with [open] buttons, free exit and/or open only devices.
003	CLOSE	Close only. Used with [close] buttons and closing loop detectors
004	PED	Pedestrian opening. Partially opens Motor 1 only.
005	TIMER	Hold Open input.
006	TIMER PED	Holds partially open motor 1

SAFE Values (terminals 71 & 73)

LOGIC > SAFE# > 000 ~ 008

VALUE	FUNCTION	DESCRIPTION
000	PHOT	System reacts to the input in both opening (stops) and closing (reverses) cycles
001	PHOT TEST	Same as above. Requires the device to be supervised (FAULT active)
002	PHOT OP	System reacts to the input only during the opening cycle (stops)
003	PHOT OP TEST	Same as above. Requires the device to be supervised (FAULT active)
004	PHOT CL	System reacts to the input only during the closing cycle (reverses)
005	PHOT CL TEST	Same as above. Requires the device to be supervised (FAULT active)
006	BAR	Safety edge input. It reacts in both opening and closing. Stops and partially reverses.
007	BAR TEST	Same as above. Requires the device to be supervised (FAULT active)
008	BAR 9K2	Safety edge input with EOL resistor as supervision method.