

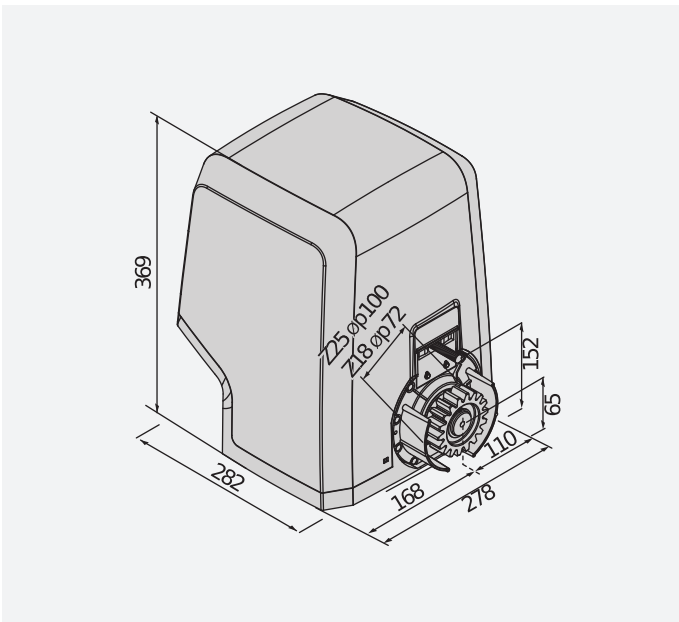

230V sliding gate operators for very intensive use, extremely sturdy and high-performance thanks to oil bath transmission. Control of torque via D-track technology and absolute encoder for maximum precision of movement. Control unit arranged for communication with U-link protocol and with tamper-proof function. The control unit ensures complete safety thanks to the exclusive torque control system that makes these operators comply fully with the current European standards.

## DIMENSION (MM)



## TECHNICAL FEATURES

	ICARO SMART AC A2000	ICARO SMART AC A2000 SQ	ICARO SMART AC A2000 V	ICARO SMART AC A2000 V SQ	ICARO SMART AC A2000 120	ICARO SMART AC A2000 V 120
Control unit	LEO B CBB L 02	Not present	LEO B CBB L 02	Not present	LEO B CBB L 02 120V	
Board power supply	230 V	no V	230 V	no V	230 V	230 V
Supply voltage AC	230 V	230 V	230 V	230 V	120 V	120 V
Power input	750 W	750 W	750 W	750 W	750 W	750 W
Max. door/gate weight	2000 kg	2000 kg	1000 kg	2000 kg	2000 kg	2000 kg
Gate speed	9 m/min	9 m/min	12 m/min	12 m/min	9 m/min	12 m/min
Type of limit switch	Electromechanical	Electromechanical	Electromechanical	Electromechanical	Electromechanical	Electromechanical
Pinion module	4	4	4	4	4	4
Slowdown	Yes	Yes	Yes	Yes	Yes	Yes
Locking	Mechanical	Mechanical	Mechanical	Mechanical	Mechanical	Mechanical
Release	Lever-operated with personal key	Lever-operated with personal key	Lever-operated with personal key	Lever-operated with personal key	Lever-operated with personal key	Lever-operated with personal key
Impact reaction	D-Track	Mechanical clutch	D-Track	Mechanical clutch	D-Track	D-Track
Frequency of use	very intensive	very intensive	very intensive	very intensive	very intensive	very intensive
Protection rating	IP24					
Environmental conditions	-15 ÷ 60 °C					

		Description	
P925236 00002	ICARO SMART AC A2000	Operator 230 V for sliding gates up to 2000 kg with absolute encoder. Leaf speed 9 m/min. Limit switch Electromechanical. Equipped with mechanical safety clutch, torque management via D-track technology and gear unit in oil bath. Control unit arranged for communication with U-link protocol and tamper-proof function. Absolute encoder and torque management with D-track system.	U-Link
P925236 00003	ICARO SMART AC A2000 SQ	Operator 230 V for sliding gates up to 2000 kg in weight. Leaf speed 9 m/min. Limit switch Electromechanical. Equipped with mechanical safety clutch.	
P925237 00002	ICARO SMART AC A2000 V	Operator 230 V for sliding gates up to 1000 kg with absolute encoder. Leaf speed 12 m/min. Limit switch Electromechanical. Equipped with mechanical safety clutch, torque management via D-track technology and gear unit in oil bath. Control unit arranged for communication with U-link protocol and tamper-proof function. Operator with absolute encoder and torque management with D-track system.	U-Link
P925237 00003	ICARO SMART AC A2000 V SQ	Operator 230 V for sliding gates up to 2000 kg in weight. Leaf speed 12 m/min. Limit switch Electromechanical. Equipped with mechanical safety clutch.	U-Link
P925236 00001	ICARO SMART AC A2000 120	Operator 120 V for sliding gates up to 2000 kg with absolute encoder. Leaf speed 9 m/min. Limit switch Electromechanical. Equipped with mechanical safety clutch, torque management via D-track technology and gear unit in oil bath. Control unit arranged for communication with U-link protocol and tamper-proof function. Operator with absolute encoder and torque management with D-track system.	U-Link
P925237 00001	ICARO SMART AC A2000 V 120	Operator 120 V for sliding gates up to 2000 kg with absolute encoder. Leaf speed 12 m/min. Limit switch Electromechanical. Equipped with mechanical safety clutch, torque management via D-track technology and gear unit in oil bath. Control unit arranged for communication with U-link protocol and tamper-proof function. Operator with absolute encoder and torque management with D-track system.	U-Link

### LEO B CBB L02: Incorporated control unit for one 230V operator for sliding gates.

#### LEO B CBB L02 - Built-In



- Incorporated control unit for one 230V operator for sliding gates
- Application: built-in control unit for one 230V operator for sliding gates
- Board power supply: 230V single-phase
- Operator power supply: 230V 750W
- Main features: removable terminal blocks with new standard colour-coding, simplified scenario-based programming with display, incorporated dual channel receiver, D-Track anti-crushing system, slowdown during opening and closing
- Main functions: automatic re-closing, fast closing, pedestrian opening

## RECOMMENDED ACCESSORIES

	D221073 - CP plastic rack, 4-module, cross-section 22 x 22 mm, length 1 m, screw-fitted into slots. Max. load capacity 600 kg.		N999320 - CVZ-S steel rack, 4-module, cross-section 30 x 8 mm, length 1 m, screw-fitted on supports. Max. load capacity 800 kg.
	D571053 - CVZ steel rack, 4-module, cross-section 30 x 12 mm, length 1 m, screw-fitted on supports. Max. load capacity 1000 kg.		D571054 - CFZ galvanized steel rack, 4-module, cross-section 22 x 22 mm, length 2 m, welding. Max. load capacity 2000 kg.
	N999156 - SFI Base plate for ARES and ICARO (supplied with operator).		P125018 - THEKE B PRA 01 Metal protection box for ARES and ICARO series sliding operators.