

AUTOMAZIONI A PISTONE PER CANCELLI A BATTENTE  
PISTON AUTOMATION FOR SWING GATES  
AUTOMATIONS A PISTON POUR PORTAILS BATTANTS  
KOLBEN AUTOMATIONEN FÜR FLÜGELGITTERTORE  
AUTOMATIZACIONES A PISTON PARA PORTONES CON BATIENDE  
AUTOMATIZAÇÃO A PISTÃO PARA PORTÕES COM BATENTE

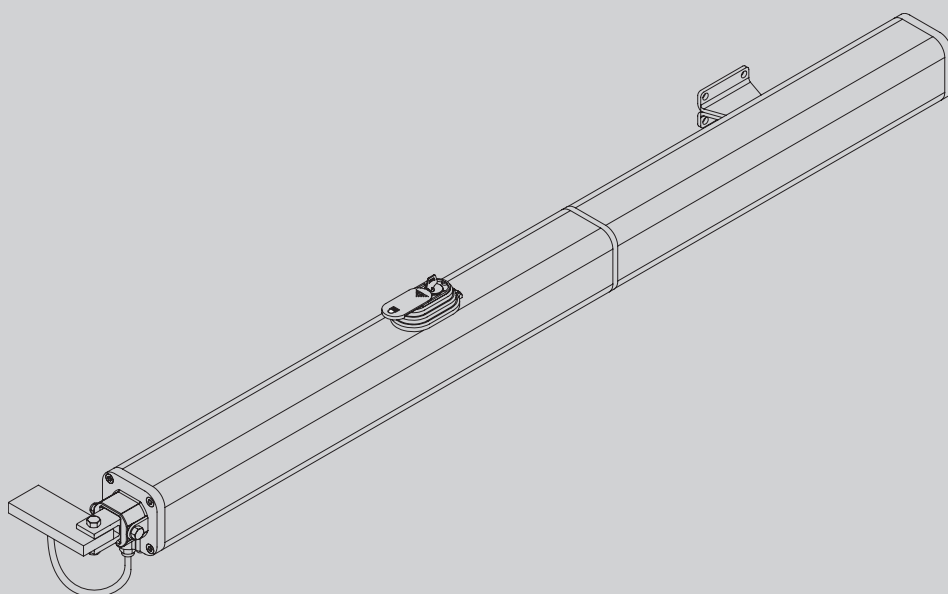

# P7-P4.5

ISTRUZIONI D'USO E DI INSTALLAZIONE  
INSTALLATION AND USER'S MANUAL  
INSTRUCTIONS D'UTILISATION ET D'INSTALLATION  
INSTALLATIONS-UND GEBRAUCHSANLEITUNG  
INSTRUCCIONES DE USO Y DE INSTALACION  
INSTRUÇÕES DE USO E DE INSTALAÇÃO



AZIENDA CON SISTEMA DI GESTIONE  
INTEGRATO CERTIFICATO DA DNV  
= UNI EN ISO 9001:2008 =  
UNI EN ISO 14001:2004

**Attenzione!** Leggere attentamente le "Avvertenze" all'interno! **Caution!** Read "Warnings" inside carefully! **Attention!** Veuillez lire attentivement les Avertissements qui se trouvent à l'intérieur!  
**Achtung!** Bitte lesen Sie aufmerksam die „Hinweise“ im Inneren! **¡Atención!** Leer atentamente las "Advertencias" en el interior! **Atenção!** Ler atentamente as "Instruções" que se encontram no interior!

www.BFTGateOpeners.com | (800) 878-7829 | Sales@BFTGateOpeners.com

## INSTALLER WARNINGS

**WARNING! Important safety instructions. Carefully read and comply with all the warnings and instructions that come with the product as incorrect installation can cause injury to people and animals and damage to property. The warnings and instructions give important information regarding safety, installation, use and maintenance. Keep hold of instructions so that you can attach them to the technical file and keep them handy for future reference.**

### GENERAL SAFETY

This product has been designed and built solely for the purpose indicated herein. Uses other than those indicated herein might cause damage to the product and create a hazard.

- The units making up the machine and its installation must meet the requirements of the following European Directives, where applicable: 2004/108/EC, 2006/95/EC, 2006/42/EC, 89/106/EC, 99/05/EC and later amendments. For all countries outside the EEC, it is advisable to comply with the standards mentioned, in addition to any national standards in force, to achieve a good level of safety.
- The Manufacturer of this product (hereinafter referred to as the "Firm") disclaims all responsibility resulting from improper use or any use other than that for which the product has been designed, as indicated herein, as well as for failure to apply Good Practice in the construction of entry systems (doors, gates, etc.) and for deformation that could occur during use.
- Installation must be carried out by qualified personnel (professional installer, according to EN 12635), in compliance with Good Practice and current code.
- Before installing the product, make all structural changes required to produce safety gaps and to provide protection from or isolate all crushing, shearing and dragging hazard areas and danger zones in general in accordance with the provisions of standards EN 12604 and 12453 or any local installation standards. Check that the existing structure meets the necessary strength and stability requirements.
- Before commencing installation, check the product for damage.
- The Firm is not responsible for failure to apply Good Practice in the construction and maintenance of the doors, gates, etc. to be motorized, or for deformation that might occur during use.
- Make sure the stated temperature range is compatible with the site in which the automated system is due to be installed.
- Do not install this product in an explosive atmosphere: the presence of flammable fumes or gas constitutes a serious safety hazard.
- Disconnect the electricity supply before performing any work on the system. Also disconnect buffer batteries, if any are connected.
- Before connecting the power supply, make sure the product's ratings match the mains ratings and that a suitable residual current circuit breaker and overcurrent protection device have been installed upline from the electrical system. Have the automated system's mains power supply fitted with a switch or omnipolar thermal-magnetic circuit breaker with a contact separation that provide full disconnection under overvoltage category III conditions.
- Make sure that upline from the mains power supply there is a residual current circuit breaker that trips at no more than 0.03A as well as any other equipment required by code.
- Make sure the earth system has been installed correctly: earth all the metal parts belonging to the entry system (doors, gates, etc.) and all parts of the system featuring an earth terminal.
- Installation must be carried out using safety devices and controls that meet standards EN 12978 and EN 12453.
- Impact forces can be reduced by using deformable edges.
- In the event impact forces exceed the values laid down by the relevant standards, apply electro-sensitive or pressure-sensitive devices.
- Apply all safety devices (photocells, safety edges, etc.) required to keep the area free of impact, crushing, dragging and shearing hazards. Bear in mind the standards and directives in force, Good Practice criteria, intended use, the installation environment, the operating logic of the system and forces generated by the automated system.
- Apply all signs required by current code to identify hazardous areas (residual risks). All installations must be visibly identified in compliance with the provisions of standard EN 13241-1.
- Once installation is complete, apply a nameplate featuring the door/gate's data.
- This product cannot be installed on leaves incorporating doors (unless the motor can be activated only when the door is closed).
- If the automated system is installed at a height of less than 2.5 m or is accessible, the electrical and mechanical parts must be suitably protected.
- For roller shutter automation only
  - 1) The motor's moving parts must be installed at a height greater than 2.5 m above the floor or other surface from which they may be reached.
  - 2) The gearmotor must be installed in a segregated and suitably protected space so that it cannot be reached without the aid of tools.
- Install any fixed controls in a position where they will not cause a hazard, away from moving parts. More specifically, hold-to-run controls must be positioned within direct sight of the part being controlled and, unless they are key operated, must be installed at a height of at least 1.5 m and in a place where they cannot be reached by the public.
- Apply at least one warning light (flashing light) in a visible position, and also attach a Warning sign to the structure.
- Attach a label near the operating device, in a permanent fashion, with information on how to operate the automated system's manual release.
- Make sure that, during operation, mechanical risks are avoided or relevant protective measures taken and, more specifically, that nothing can be banged, crushed, caught or cut between the part being operated and surrounding parts.
- Once installation is complete, make sure the motor automation settings are correct and that the safety and release systems are working properly.
- Only use original spare parts for any maintenance or repair work. The Firm disclaims all responsibility for the correct operation and safety of the automated system if parts from other manufacturers are used.
- Do not make any modifications to the automated system's components unless explicitly authorized by the Firm.
- Instruct the system's user on what residual risks may be encountered, on the control systems that have been applied and on how to open the system manually in an emergency. Give the user guide to the end user.

-Dispose of packaging materials (plastic, cardboard, polystyrene, etc.) in accordance with the provisions of the laws in force. Keep nylon bags and polystyrene out of reach of children.

### WIRING

**WARNING!** For connection to the mains power supply, use a multicore cable with a cross-sectional area of at least 5x1.5mm<sup>2</sup> or 4x1.5mm<sup>2</sup> when dealing with three-phase power supplies or 3x1.5mm<sup>2</sup> for single-phase supplies (by way of example, type H05 VV-F cable can be used with a cross-sectional area of 4x1.5mm<sup>2</sup>). To connect auxiliary equipment, use wires with a cross-sectional area of at least 0.5 mm<sup>2</sup>.

- Only use pushbuttons with a capacity of 10A-250V or more.
- Wires must be secured with additional fastening near the terminals (for example, using cable clamps) in order to keep live parts well separated from safety extra low voltage parts.
- During installation, the power cable must be stripped to allow the earth wire to be connected to the relevant terminal, while leaving the live wires as short as possible. The earth wire must be the last to be pulled taut in the event the cable's fastening device comes loose.

**WARNING!** safety extra low voltage wires must be kept physically separate from low voltage wires.

Only qualified personnel (professional installer) should be allowed to access live parts.

### CHECKING THE AUTOMATED SYSTEM AND MAINTENANCE

Before the automated system is finally put into operation, and during maintenance work, perform the following checks meticulously:

- Make sure all components are fastened securely.
- Check starting and stopping operations in the case of manual control.
- Check the logic for normal or personalized operation.
- For sliding gates only: check that the rack and pinion mesh correctly with 2 mm of play along the full length of the rack; keep the track the gate slides on clean and free of debris at all times.
- For sliding gates and doors only: make sure the gate's running track is straight and horizontal and that the wheels are strong enough to take the weight of the gate.
- For cantilever sliding gates only: make sure there is no dipping or swinging during operation.
- For swing gates only: make sure the leaves' axis of rotation is perfectly vertical.
- For barriers only: before opening the door, the spring must be decompressed (vertical boom).
- Check that all safety devices (photocells, safety edges, etc.) are working properly and that the anti-crush safety device is set correctly, making sure that the force of impact measured at the points provided for by standard EN 12445 is lower than the value laid down by standard EN 12453.
- Impact forces can be reduced by using deformable edges.
- Make sure that the emergency operation works, where this feature is provided.
- Check opening and closing operations with the control devices applied.
- Check that electrical connections and cabling are intact, making extra sure that insulating sheaths and cable glands are undamaged.
- While performing maintenance, clean the photocells' optics.
- When the automated system is out of service for any length of time, activate the emergency release (see "EMERGENCY OPERATION" section) so that the operated part is made idle, thus allowing the gate to be opened and closed manually.
- If the power cord is damaged, it must be replaced by the manufacturer or their technical assistance department or other such qualified person to avoid any risk.
- If "D" type devices are installed (as defined by EN12453), connect in unverified mode, foresee mandatory maintenance at least every six months
- The maintenance described above must be repeated at least once yearly or at shorter intervals where site or installation conditions make this necessary.

### WARNING!

Remember that the drive is designed to make the gate/door easier to use and will not solve problems as a result of defective or poorly performed installation or lack of maintenance



### SCRAPPING

Materials must be disposed of in accordance with the regulations in force. Do not throw away your discarded equipment or used batteries with household waste. You are responsible for taking all your waste electrical and electronic equipment to a suitable recycling centre.

### DISMANTLING

If the automated system is being dismantled in order to be reassembled at another site, you are required to:

- Cut off the power and disconnect the whole electrical system.
- Remove the actuator from the base it is mounted on.
- Remove all the installation's components.
- See to the replacement of any components that cannot be removed or happen to be damaged.

**DECLARATIONS OF CONFORMITY CAN BE FOUND AT <http://www.bft-automation.com/CE>  
INSTRUCTIONS FOR USE AND ASSEMBLY CAN BE FOUND IN THE DOWN-LOAD SECTION.**

**Anything that is not explicitly provided for in the installation manual is not allowed. The operator's proper operation can only be guaranteed if the information given is complied with. The Firm shall not be answerable for damage caused by failure to comply with the instructions featured herein.**

**While we will not alter the product's essential features, the Firm reserves the right, at any time, to make those changes deemed opportune to improve the product from a technical, design or commercial point of view, and will not be required to update this publication accordingly.**

## USER WARNINGS (GB)

**WARNING! Important safety instructions. Carefully read and comply with the Warnings and Instructions that come with the product as improper use can cause injury to people and animals and damage to property. Keep the instructions for future reference and hand them on to any new users.**

**This product is meant to be used only for the purpose for which it was explicitly installed. Any other use constitutes improper use and, consequently, is hazardous. The manufacturer cannot be held liable for any damage as a result of improper, incorrect or unreasonable use.**

### GENERAL SAFETY

Thank you for choosing this product. The Firm is confident that its performance will meet your operating needs.

This product meets recognized technical standards and complies with safety provisions when installed correctly by qualified, expert personnel (professional installer).

If installed and used correctly, the automated system will meet operating safety standards. Nonetheless, it is advisable to observe certain rules of behaviour so that accidental problems can be avoided:

- Keep adults, children and property out of range of the automated system, especially while it is moving.
- Do not allow children to play or stand within range of the automated system.
- The unit can be used by children over 8 years old and by people with reduced physical, sensory or mental capabilities or with no experience or necessary knowledge on condition they are supervised or trained about the safe use of the equipment and understand the risks involved. Children must not play with the unit. Cleaning and maintenance must not be performed by unsupervised children.
- Children must be supervised to ensure they do not play with the device. Do not allow children to play with the fixed controls. Keep remote controls out of reach of children.
- Do not work near hinges or moving mechanical parts.
- Do not hinder the leaf's movement and do not attempt to open the door manually unless the actuator has been released with the relevant release knob.

- Keep out of range of the motorized door or gate while they are moving.
- Keep remote controls or other control devices out of reach of children in order to avoid the automated system being operated inadvertently.
- The manual release's activation could result in uncontrolled door movements if there are mechanical faults or loss of balance.
- When using roller shutter openers: keep an eye on the roller shutter while it is moving and keep people away until it has closed completely. Exercise care when activating the release, if such a device is fitted, as an open shutter could drop quickly in the event of wear or breakage.
- The breakage or wear of any mechanical parts of the door (operated part), such as cables, springs, supports, hinges, guides..., may generate a hazard. Have the system checked by qualified, expert personnel (professional installer) at regular intervals according to the instructions issued by the installer or manufacturer of the door.
- When cleaning the outside, always cut off mains power.
- Keep the photocells' optics and illuminating indicator devices clean. Check that no branches or shrubs interfere with the safety devices.
- Do not use the automated system if it is in need of repair. In the event the automated system breaks down or malfunctions, cut off mains power to the system; do not attempt to repair or perform any other work to rectify the fault yourself and instead call in qualified, expert personnel (professional installer) to perform the necessary repairs or maintenance. To allow access, activate the emergency release (where fitted).
- If any part of the automated system requires direct work of any kind that is not contemplated herein, employ the services of qualified, expert personnel (professional installer).
- At least once a year, have the automated system, and especially all safety devices, checked by qualified, expert personnel (professional installer) to make sure that it is undamaged and working properly.
- A record must be made of any installation, maintenance and repair work and the relevant documentation kept and made available to the user on request.
- Failure to comply with the above may result in hazardous situations.



### SCRAPPING

Materials must be disposed of in accordance with the regulations in force. Do not throw away your discarded equipment or used batteries with household waste. You are responsible for taking all your waste electrical and electronic equipment to a suitable recycling centre.

**Anything that is not explicitly provided for in the user guide is not allowed. The operator's proper**

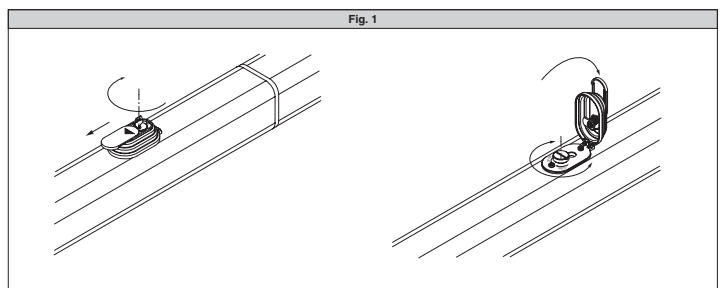

operation can only be guaranteed if the instructions given herein are complied with. The Firm shall not be answerable for damage caused by failure to comply with the instructions featured herein.

While we will not alter the product's essential features, the Firm reserves the right, at any time, to make those changes deemed opportune to improve the product from a technical, design or commercial point of view, and will not be required to update this publication accordingly.

### **EMERGENCY MANOEUVRE**

In case of emergency, for example when the electrical power is disconnected, open the electric lock by means of the appropriate key to release the gate, and open the leaf manually; you may also reach the release knob to facilitate the manoeuvre. In order to get access to the release knob, move the small cap in the direction indicated by the arrow (fig.1) to reveal the lock, insert the key, turn it clockwise by 90° and lift the entire release cover by pulling with the key. The knob must be allowed to turn as far as possible in the direction indicated by the arrows.

**OPEN** to release: the gate can be opened manually with ease.

**CLOSE** to lock : turn the knob clockwise until it is completely locked, and so restore the actuator electrical operation.

The electric lock can also be used to keep the block of the gate in case of actuator malfunction or current failure.

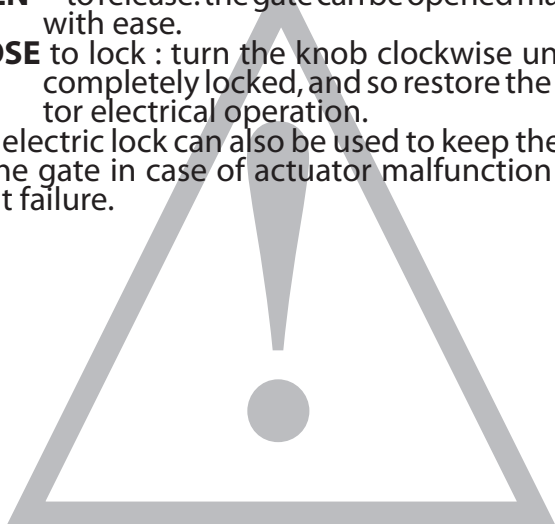

Fig. 1

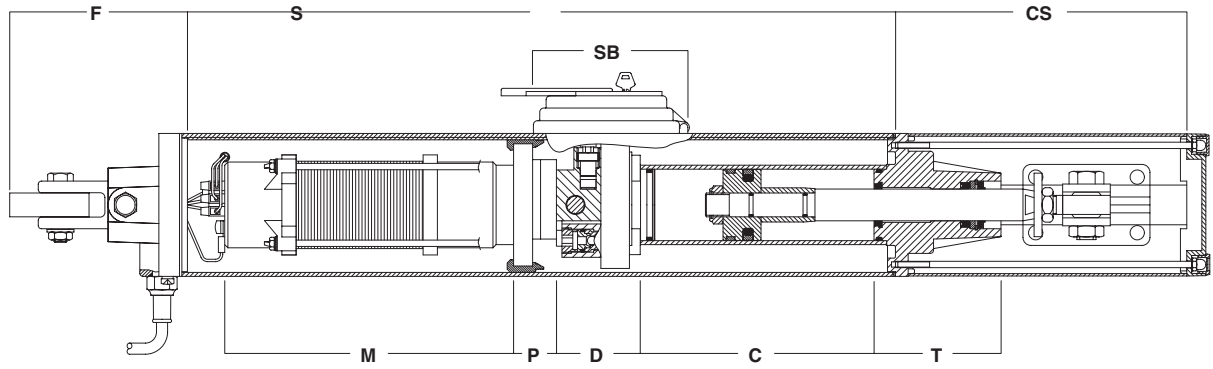
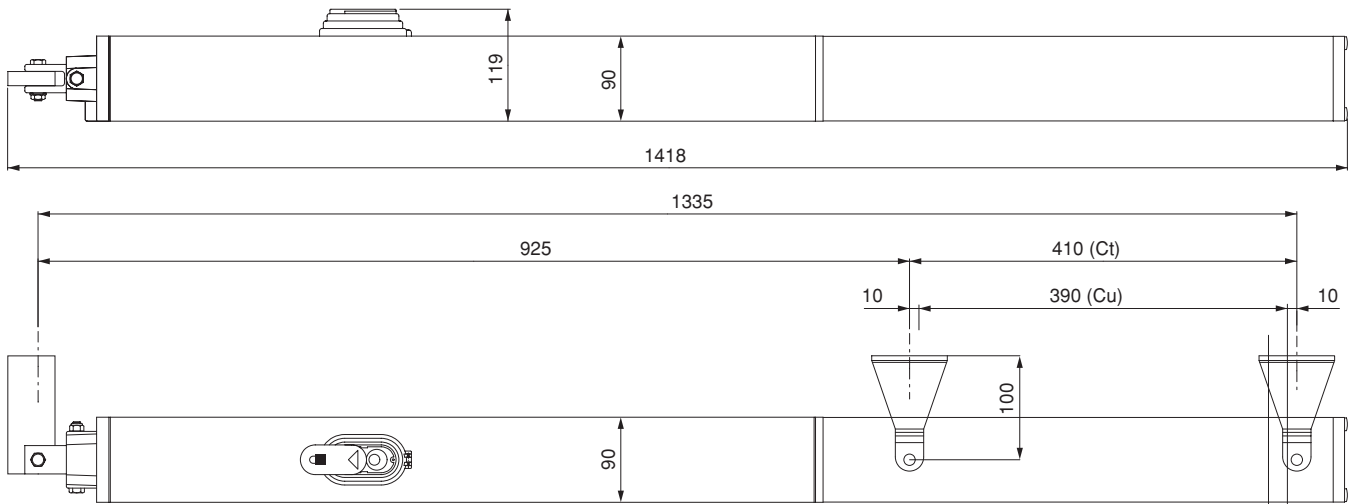

Fig. 2



Ct = Corsa totale  
Total stroke  
Course totale  
Totalhub  
Carrera total  
Curso total

Cu = Corsa utile  
Working stroke  
Course utile  
Nutzhub  
Carrera útil  
Curso útil

Cr = Corsa rallentamento  
Slow-down stroke  
Course de ralentissement  
Verlangsamungsstrecke  
Carrera de deceleraciùn  
Curso desaceleraçào

20 (Cr)

Fig. 3

a (mm) \ b (mm)	120	135	150	165	180	195	210	225	240	255	270	285
120						117	109	103	99	95	92	
135					123	111	104	99	95	92		
150					114	105	99	95	92			
165				123	107	100	95	91				
180				109	100	95	91					
195			118	101	95	90						
210			103	95	90							
225		106	95	89								
240		95	89									
255	95	88										
270	88											
285												a

Fig. 4

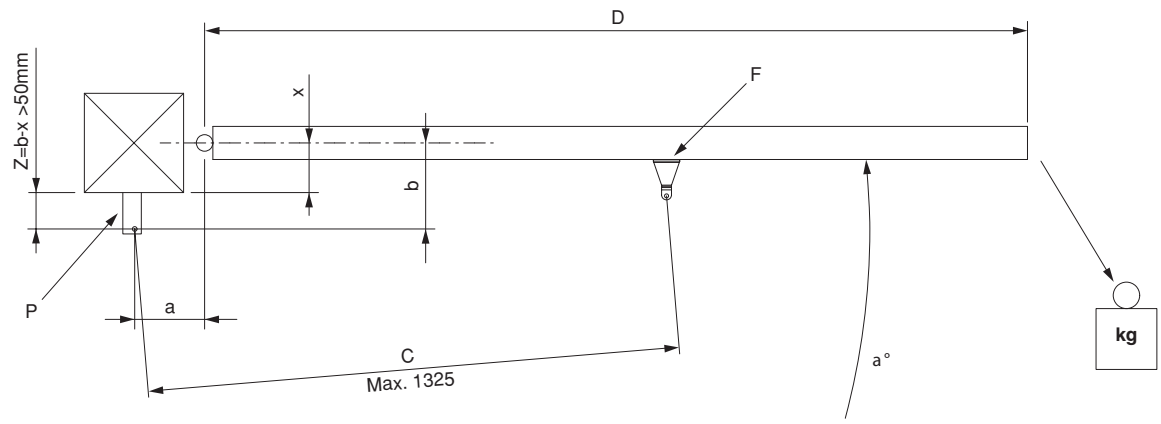

Fig. 5

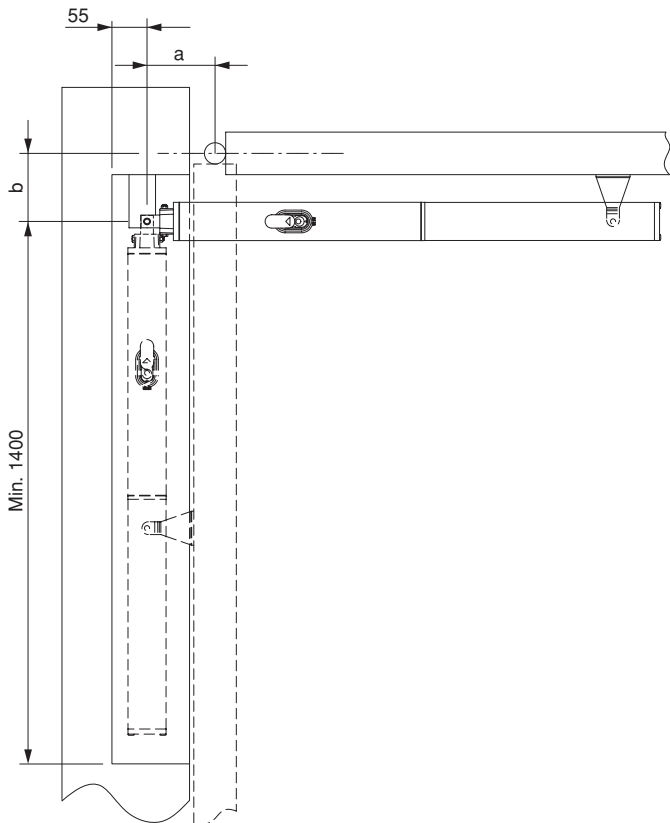

Fig. 6

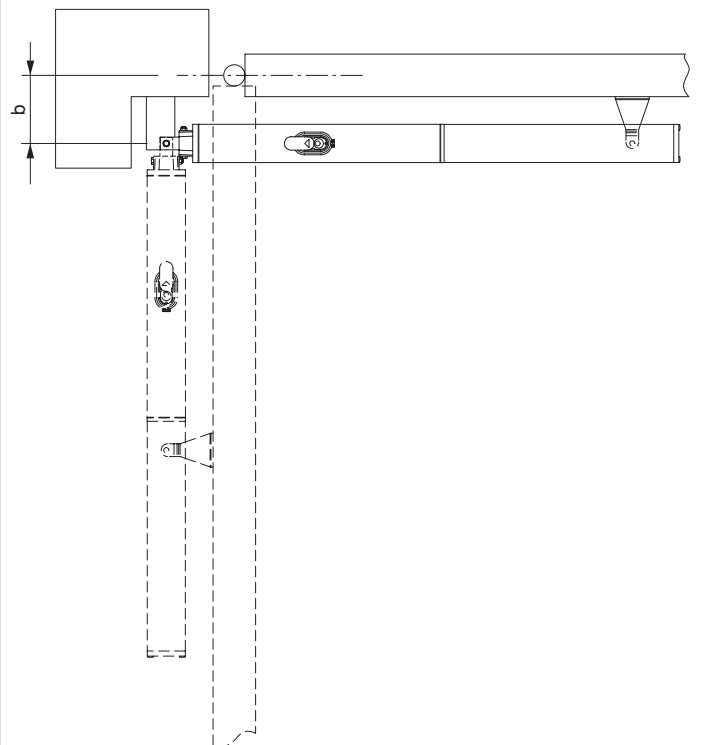

Fig. 7

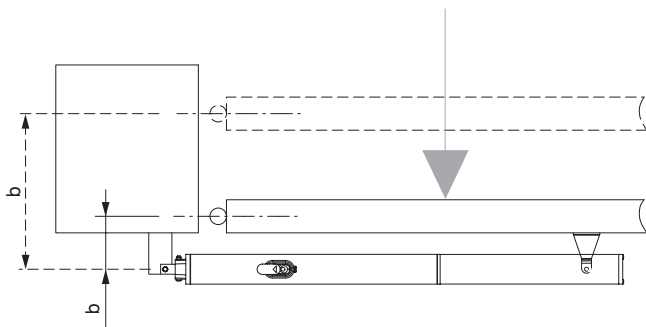

Fig. 8

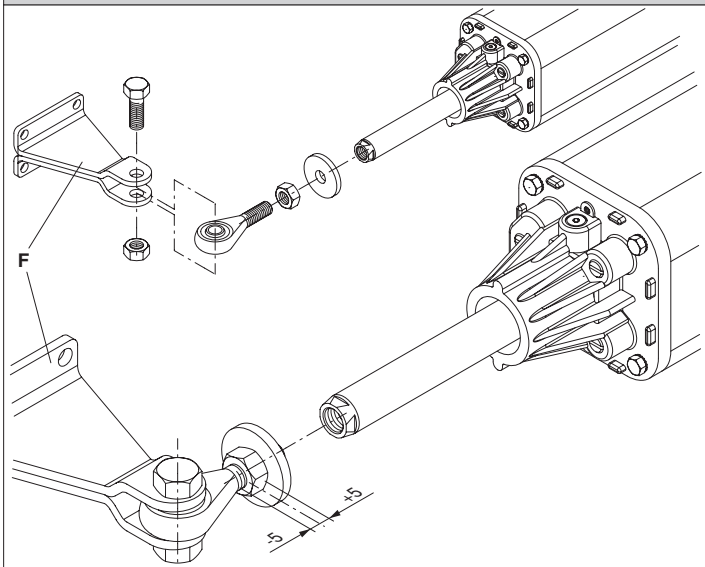

Fig. 9

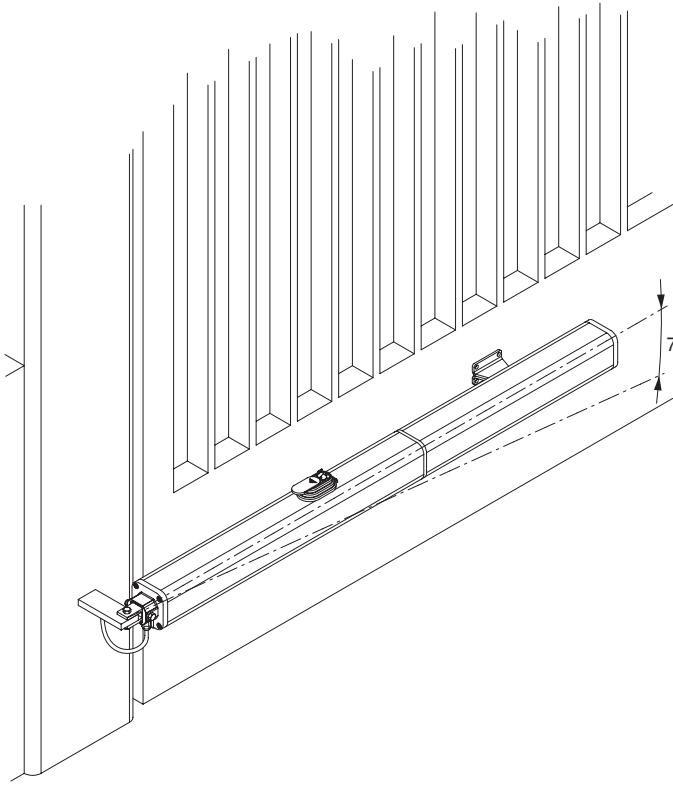

Fig. 10

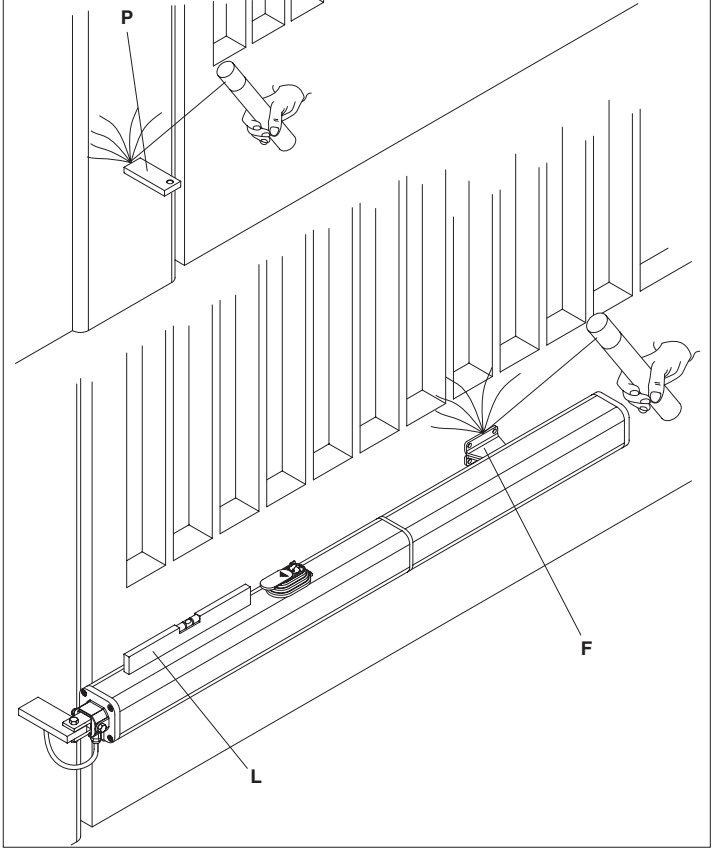

Fig. 11

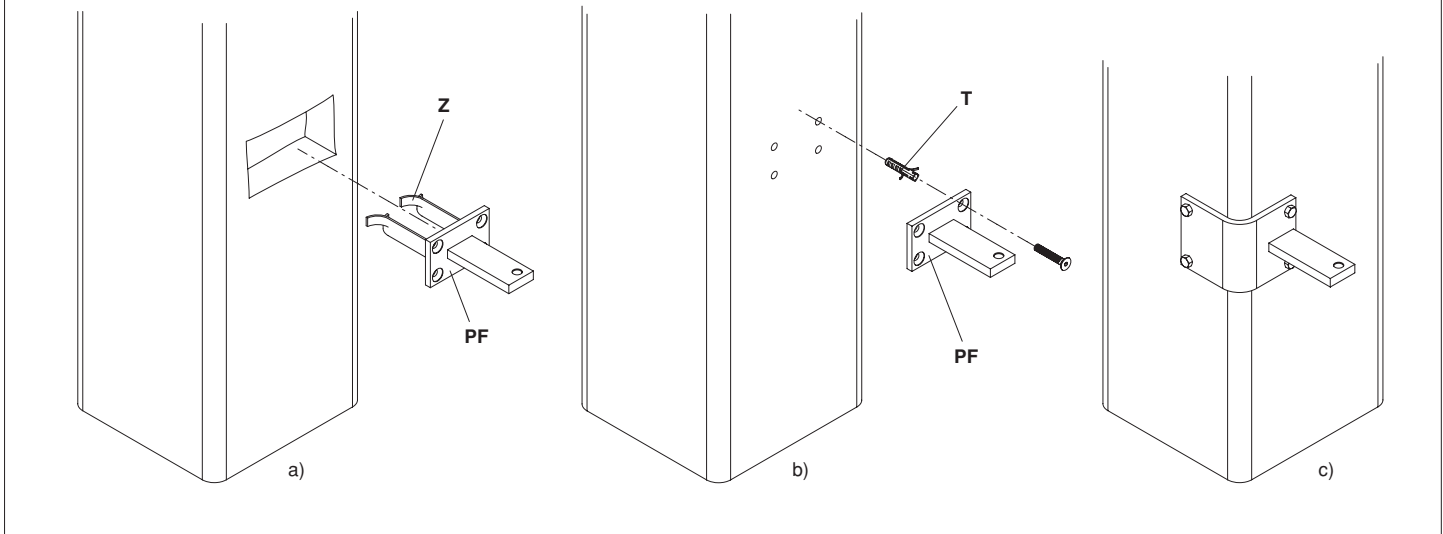

Fig. 12

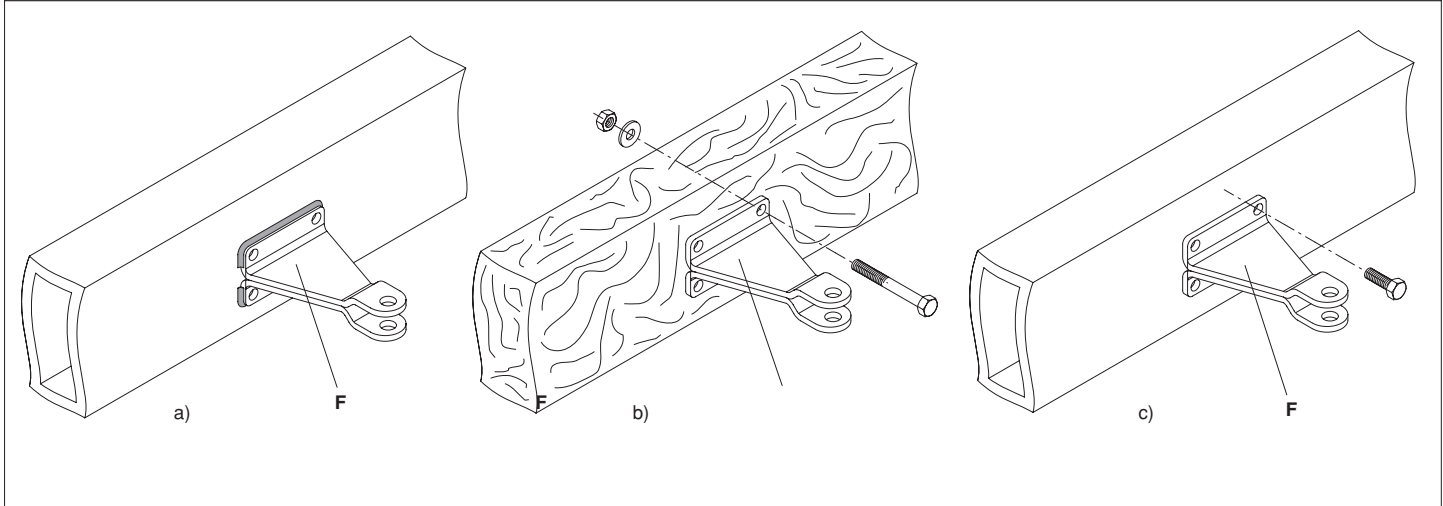

Fig. 13

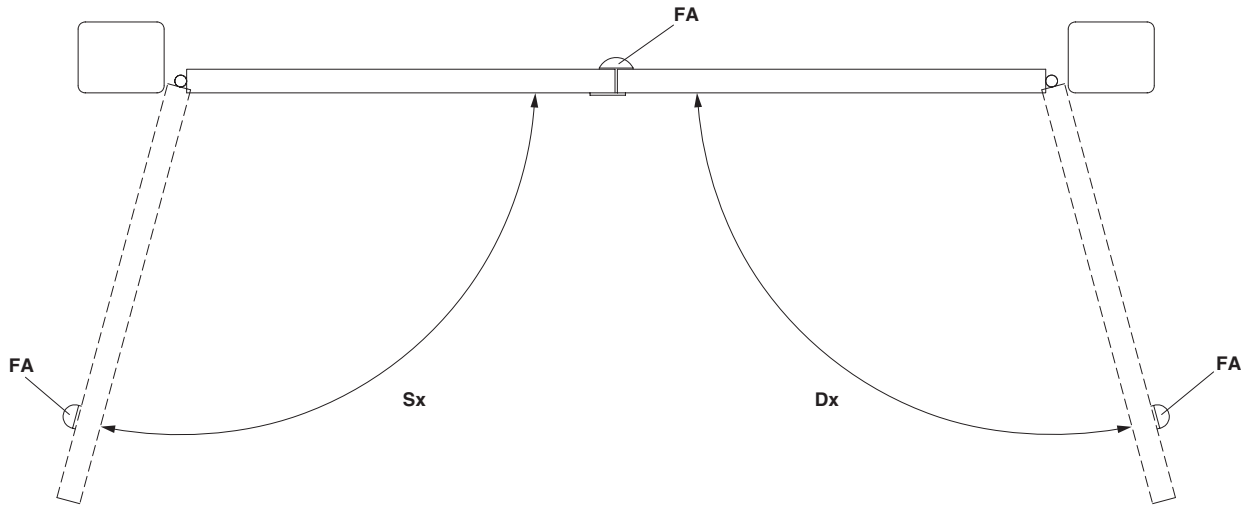

Fig. 14

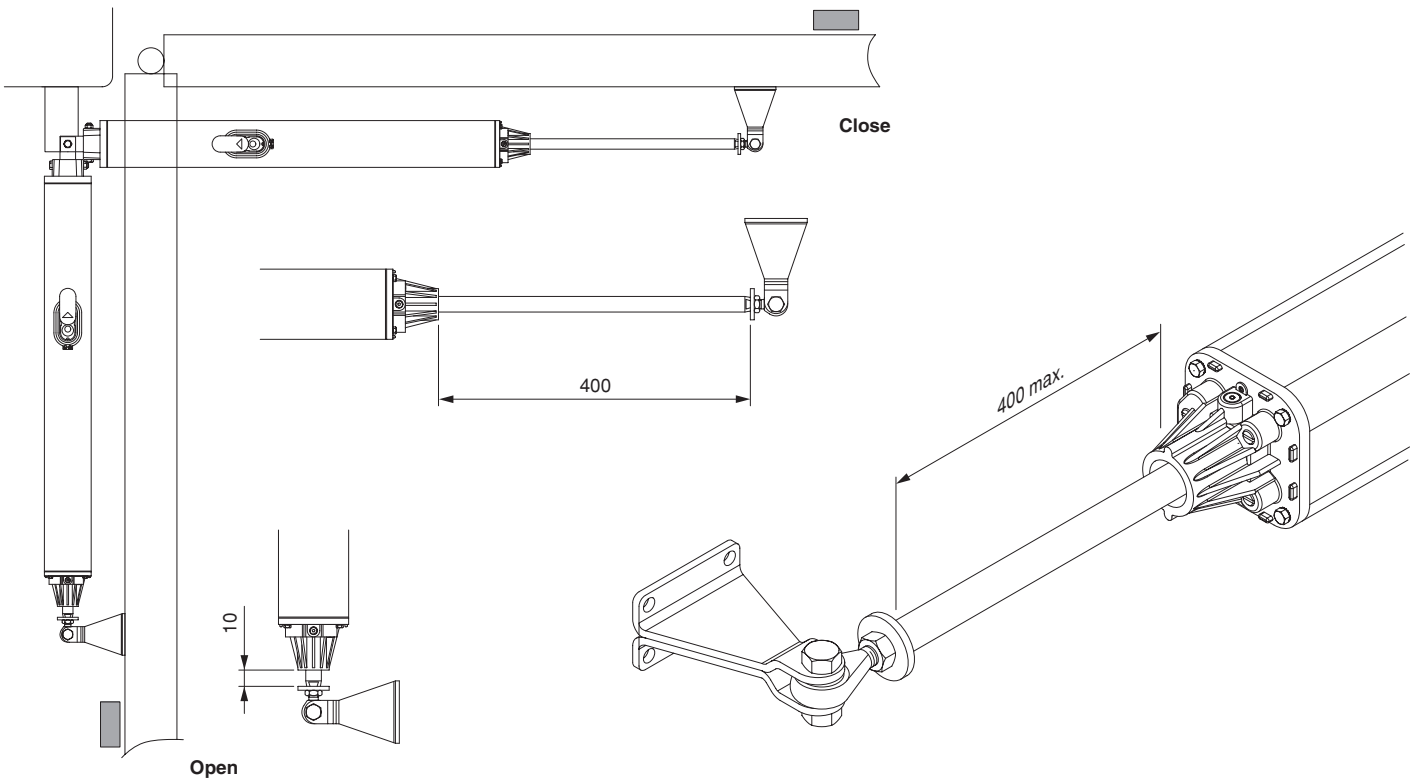

Fig. 15

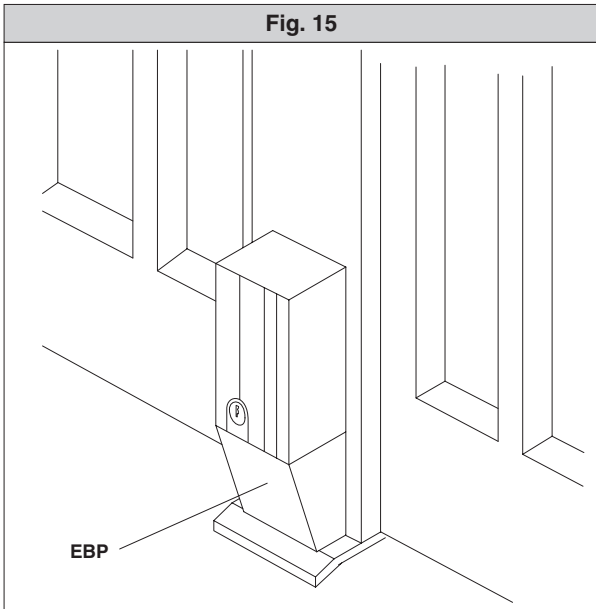

Fig. 16

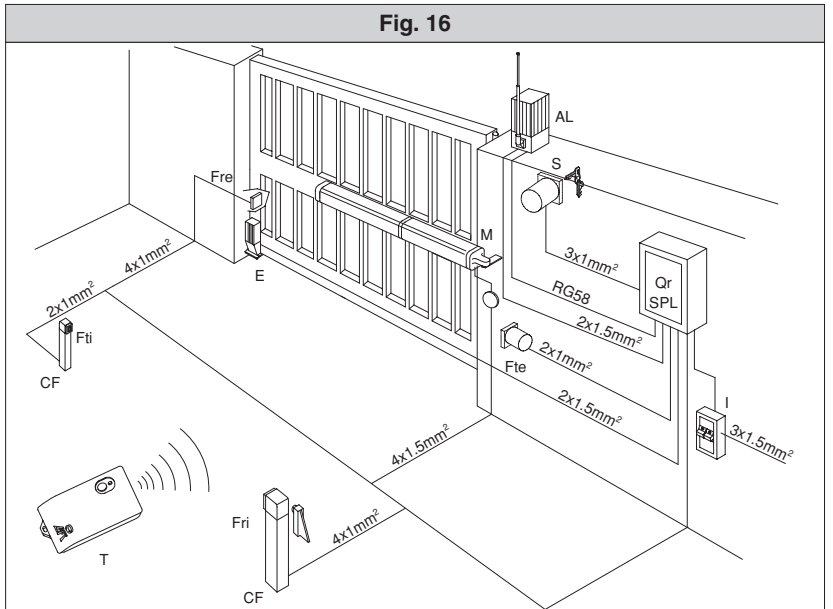



Fig. 17

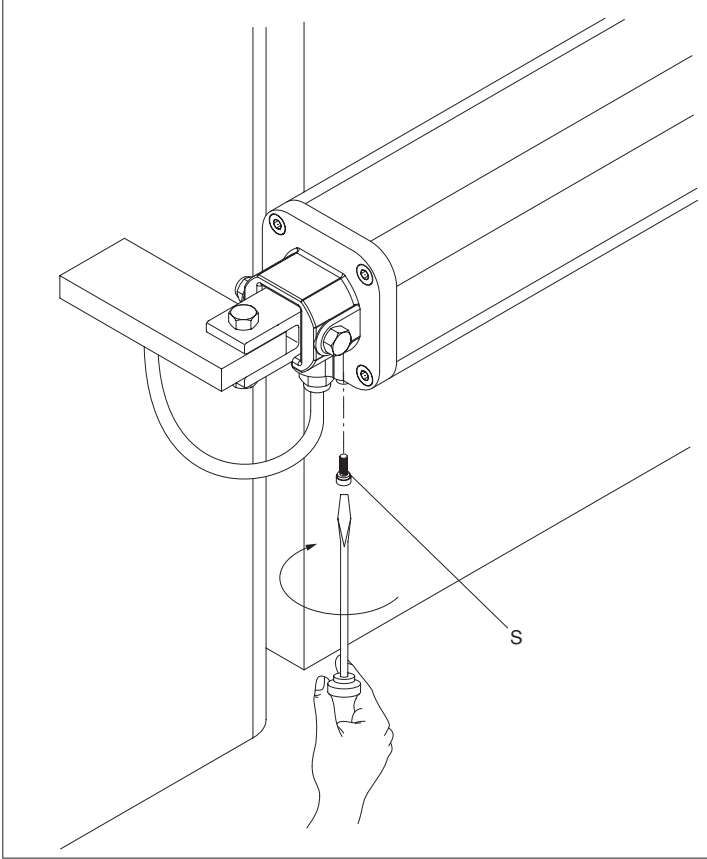

Fig. 18

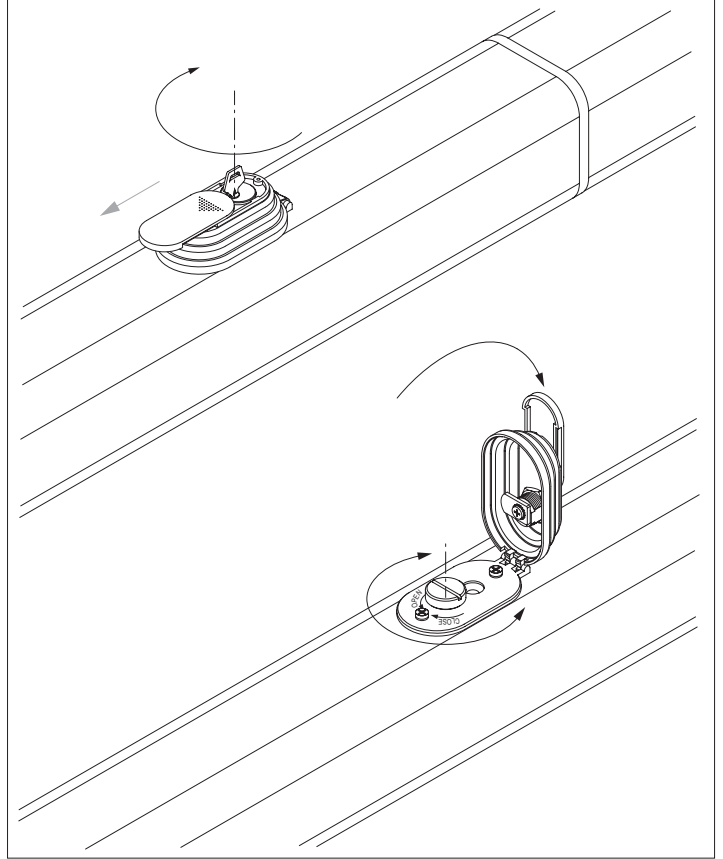

Fig. 19

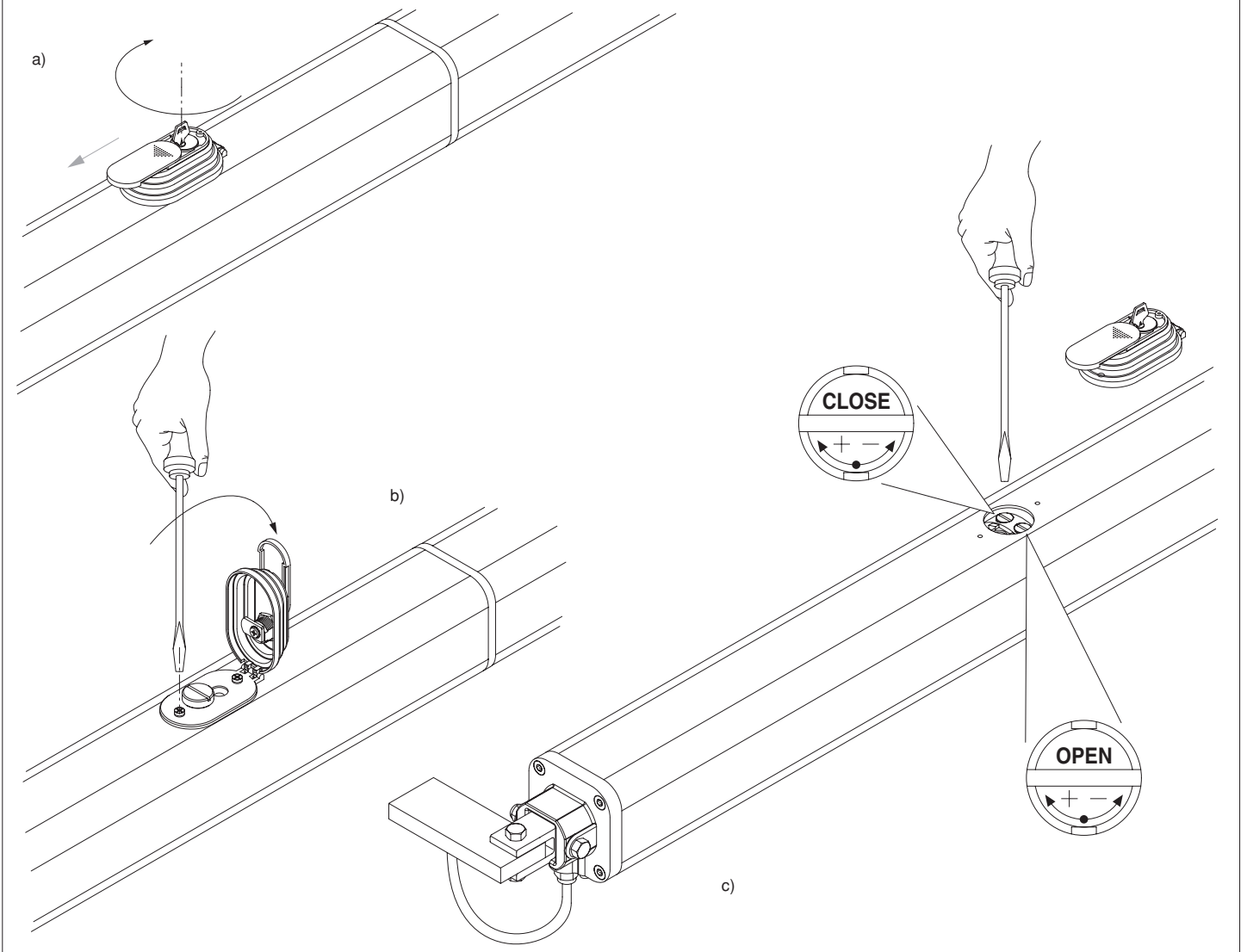

Fig. 20

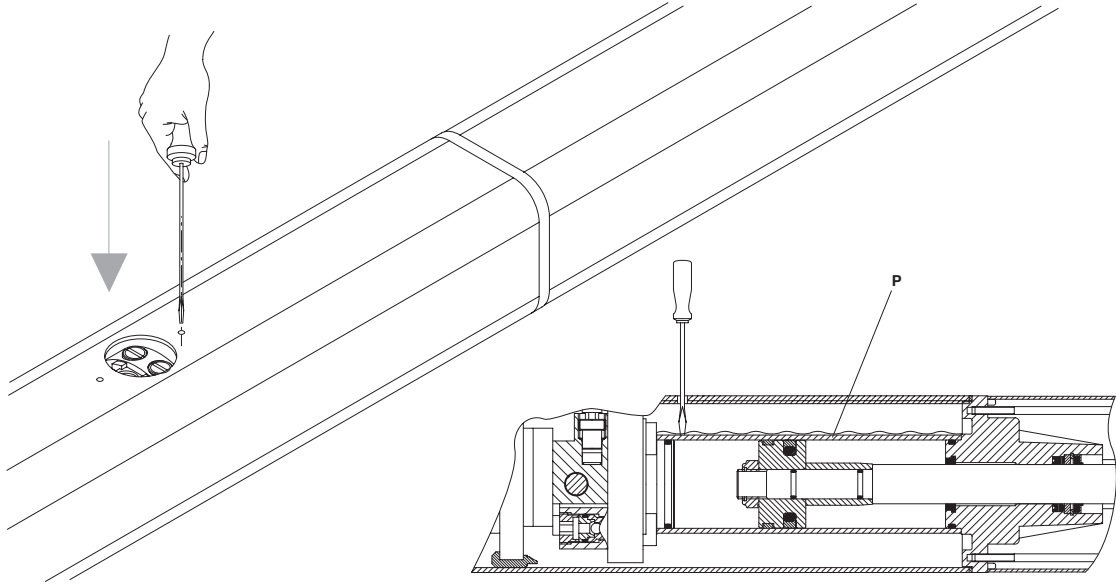

Fig. 21

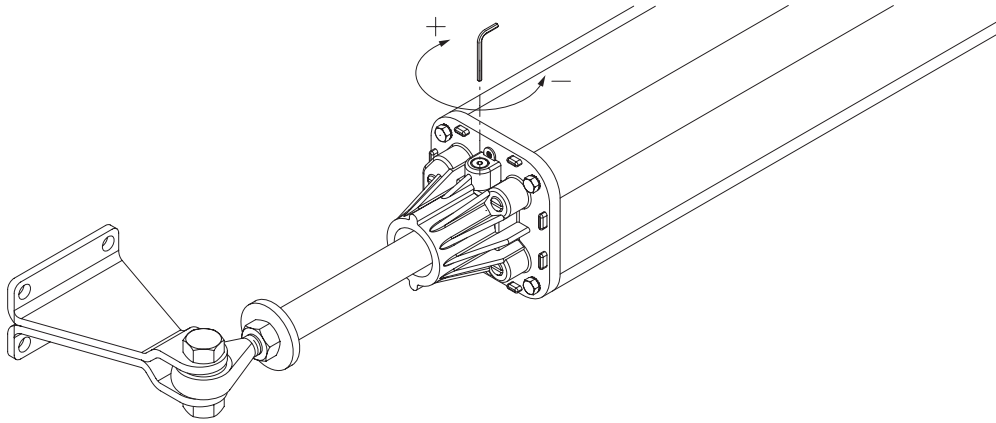
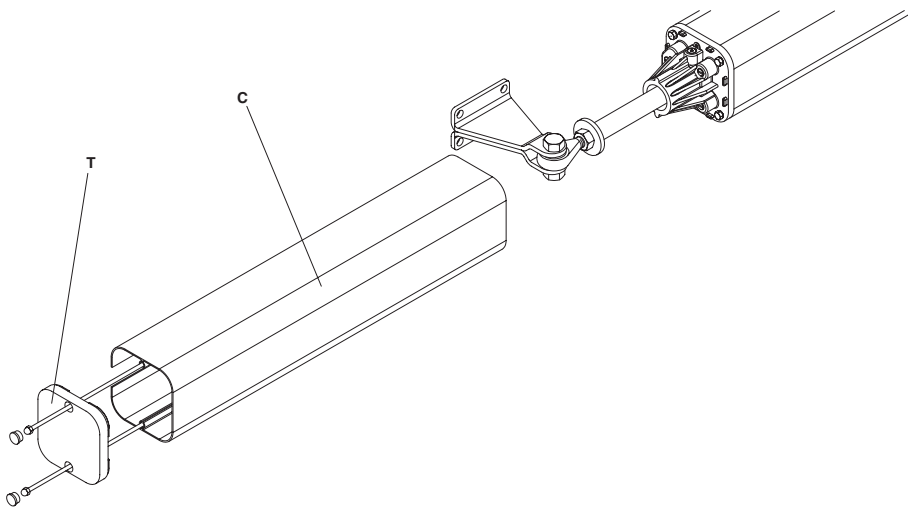

Fig. 22



**2) GENERAL OUTLINE**

A compact sturdy hydraulic piston, available in various versions according to the user's requirements and type of operation. All models are supplied without locks (reversible), and an electric lock is required to keep them blocked. To make the manual manoeuvre easier, the lock can be released by means of a knob which can be reached using the appropriate key. The pushing force is adjusted with extreme precision by means of two bypass valves which provide antisquash safety. The end-of-stroke operation is electronically set in the control panel by means of a timer. All models are available with slow-down function during the closing phase.

**3) MAIN AUTOMATION PARTS (Fig.1)**

- M)** 2-pole single-phase motor, protected by thermal circuit-breaker.
- N)** Hydraulic lobe pump.
- O)** Distributor with adjustment valves.
- P)** Cylinder with piston.
- CS)** Rod cover.
- S)** Tank.
- SB)** Release.
- T)** Head with slow-down adjustment valve.
- U)** Base with articulated joint.

Components supplied: Attachments for pillars and gate - personalised release key - drive capacitor - instruction manual.

**4) TECHNICAL SPECIFICATIONS**

**Mod. P7 - Mod. P4.5**

Power supply .....	220-230V 50/60Hz(*)
Motor .....	2800min <sup>-1</sup>
Absorbed power .....	250W
Capacitor .....	8µF
Absorbed current .....	1.1A
Max. pressure .....	5MPa (50bar) - 4MPa (40bar)
Pump capacity .....	0.6l/min - 0.9l/min
Pushing force .....	8000N - 6500N
Towing force .....	6500N - 5200N
Opening time (working stroke) .....	45s - 30s
Closing time (working stroke) .....	42s+slow-down - s 28s+slow-down
Type of lock .....	Electric lock
Max leaf length .....	7m - 4.5m
Max. leaf weight .....	5000N (~500kg)
Working stroke .....	390mm
Slow-down stroke .....	20mm
Mechanical slow-down .....	On closing
Manoeuvres in 24 hours .....	500
Impact reaction .....	Hydraulic clutch
Manual manoeuvre .....	Release key
Thermal protection .....	160°C
Environmental conditions .....	-10°C - / +60°C
Degree of protection .....	IP55
Controller weight .....	122.5N (~12.25kg)
Dimensions .....	See fig.2
Oil .....	Idrolux (3 litres)
Sound pressure .....	LpA<70dbA

(\*) (Special voltage on request).

**5) ACTUATOR INSTALLATION**

**5.1) Preliminary checks**

Check that:

- The gate structure is sufficiently sturdy. Also make sure that the actuator pushes against the leaf reinforced section.
- The leaves move manually and without effort all along their stroke.
- The door stop plates are fitted at the end of both closing and opening strokes.
- If the gate has not been recently installed, check the wear condition of all components. Repair or replace faulty or worn parts. The automation reliability and safety are directly influenced by the state of the gate structure.

**5.2) Installation dimensions**

The installation dimensions can be worked out from the table concerning the respective model (fig. 3) and with reference to the diagram in fig.4. The diagram in fig. 4 uses the following conventional references:

- P** Rear bracket fixed to pillar.
- F** Leaf fixing front fork.
- a-b** Dimensions used to determine the fixing point for bracket "P".
- C** Value of fixing distance between centres.
- D** Leaf length.
- x** Distance from the leaf axis to the pillar edge.
- Z** Value always greater than 50 mm (b - x).
- kg** Max leaf weight (see Technical specifications).
- a°** Leaf opening angle.

**5.3) How to interpret the installation measurements (Fig.3)**

The "a" and "b" values can be chosen from the table (fig. 3) depending on the a°

opening degrees which are to be obtained. The table highlights the optimum "a" and "b" values for an opening of a°=90° at constant speed; in this condition, the sum of the "a" and "b" values is equal to the value of the working stroke "Cu" (fig.2).

If the "a" and "b" values used are too different, the leaf movement is not constant, and the towing-pushing force and movement speed may vary during manoeuvring. Maximum "a" and "b" values develop maximum piston force. Warning! All versions are provided with a ball joint which allows the rod to be lengthened or shortened by approximately 5 mm, but only if it was fixed using the dimensions shown in fig. 8 before installation; after installation, this adjustment allows the rod stroke to be corrected. Fig.9 illustrates the oscillation that the controllers may show with respect to their horizontal axis. During installation, scrupulously follow all the phases described below, taking care to protect the actuator's chromium-plated rod at all times, in order to prevent it from being damaged by impact or any welding slag.

- 1) Identify "a - b - a°" in the table in fig.3.
- 2) Fix bracket "P" (fig.10) to the pillar.
- 3) Fit the piston in bracket "P".
- 4) Slacken the slow-down screw (fig.21) using the 3mm Allen wrench provided.
- 5) Pull the rod out completely after activating the emergency release (fig.18).
- 6) Push the rod back in manually by a maximum of 10 mm and tighten the emergency release (fig.18).
- 7) Fit fork "F" (fig.8) to the rod.
- 8) Fully close the gate leaf against the centre stop plate.
- 9) Keeping the piston level, mark the position for attaching fork (fig.10 ref. "F") to the leaf.
- 10) Remove fork "F" from the rod and move the piston sideways.
- 11) Fix fork (fig.10 ref. "F") to the leaf by means of screws or welding.
- 12) Reconnect the rod to fork "F" and supply the actuator with power to adjust the slow-down function.
- 13) Activate the gate to open.
- 14) Completely close the slow-down screw by turning it towards the "+" sign (fig.21) and activate the leaf closing operation. The leaf should stop before arriving at the closing position.
- 15) Slacken the adjustment screw towards the "-" sign until obtaining a slow-down speed which avoids unpleasant slamming noise. Keep in mind that slowing down can only be obtained during closing, precisely for the last 30mm of rod stroke, 10mm of which account for safety extrastroke; therefore, slowing down takes place during the last 20mm of working stroke.

**5.4) Suggestions for particular installations**

Fig.5 A recess must be made to house the controller when the leaf is completely open; the recess measurements are shown in fig. 5.

Fig.7 When the "b" dimension is greater than the values shown in the installation tables, it is necessary to move the leaf hinge-pivot or make a recess in the pillar, as in fig.6.

**5.5) Anchoring of attachments to the pillar**

Weld or fix the bracket base supplied to the pillar, check the "a" and "b" measurements and then weld plate "P" to the said base. (fig.10).

- If the pillar is made of masonry, plate "P" must be welded to the metal base "PF" and deeply anchored by means of suitable hooks "Z" which are to be welded on the back of the said base (fig. 11a).
- If the pillar is made of stone, plate "P" is welded to the metal base "PF" and can be fixed by means of four metal screw anchors "T" (fig.11b); if the gate is large, it is advisable to weld plate "P" to an angle-shaped base (fig.11c).

**5.6) Anchoring of attachments to the leaf**

Weld or fix fork "F" to the leaf at distance between centres "C" shown in fig. 4, making sure that the actuator is perfectly level (level "L", fig.10) with respect to the gate movement plane.

- If the gate is made of metal, the fork can be welded (fig.12a) or fixed using appropriate screws (fig.12c).
- If the gate is made of wood, the fork can be fixed using appropriate screws (fig.12b).

**6) GROUND LEAF STOP PLATES**

For the actuator to operate correctly, stop plates "FA" must be used during both opening and closing manoeuvres, as shown in fig.13. The leaf stop plates must prevent the actuator rod from going to the end-of- stroke position. Fig. 14 specifies the dimensions needed to check the correct actuator installation both for pushing and towing. The plates must be positioned in such a way as to maintain a rod stroke margin of approximately 10mm; this is to avoid possible operation anomalies (such as a lock-up).

**7) ELECTRIC LOCK FITTING**

This is needed on all models, as no hydraulic lock is provided either for opening or closing manoeuvres. The **EBP** model electric lock (fig.15) consists of a continuous service electromagnet being anchored to the ground. This device remains energised throughout the actuator operation time, and allows the catch to stay lifted when it reaches the closing position, without opposing any resistance; the catch will drop into position when the gate has completed the closing cycle. The electric lock can also be used to keep the block of the gate in case of actuator malfunction or current failure.

## 8) ELECTRICAL INSTALLATION SET-UP

Lay out the electrical installation (fig.16) with reference to the CEI 64-8 and IEC 364 provisions, complying with the HD 384 and other national standards in force for electrical installation. The mains power supply connections must be kept totally separate from the service connections (photocells, electric edges, control devices etc.).

**Warning!** For connection to the mains, use a multipolar cable having minimum 3x1.5mm<sup>2</sup> cross section and complying with the previously mentioned regulations (e.g.: a H07 RN-F cable with 3x1.5mm<sup>2</sup> section).

Connect the control and safety devices in compliance with the previously mentioned electrical installation standards. Fig.16 shows the number of connections and the cross section for power supply cables having a length of approximately 100 metres; in case of longer cables, calculate the cross section for the true automation load. When the auxiliary connections exceed 50-metre lengths or go through critical disturbance areas, it is recommended to decouple the control and safety devices by means of suitable relays.

### 8.1) The main automation components are (Fig.16):

I Type-approved omnipolar circuit breaker with at least 3mm contact opening, provided with protection against overloads and short circuits, suitable for cutting out automation from the mains. Place, if not already installed, a type-approved differential switch with a 0.03A threshold just before the automation system.

<b>Qr</b>	Control panel and incorporated receiver.
<b>SPL</b>	Preheating board for operation with temperature lower than 5°C (optional).
<b>S</b>	Key selector.
<b>AL</b>	Blinker with tuned antenna and RG58 cable.
<b>M</b>	Actuator.
<b>E</b>	Electric lock.
<b>Fte</b>	Pair of external photocells (emitter section).
<b>Fre</b>	Pair of external photocells (receiver section).
<b>Fti</b>	Pair of internal photocells with CF posts (emitter section).
<b>Fri</b>	Pair of internal photocells with CF posts (receiver section).
<b>T</b>	1-2-4 channel transmitter.

**Important:** Before electrically activating the actuator, remove bleed screw "S" (fig. 17) which is positioned under the articulated joint block and keep it for any later reuse. Only remove bleed screw "S" when the actuator is installed. Fit the release cover block provided, as illustrated in the drawing (fig.18). **Warning!** For the connection of the accessories, please refer to the relevant instruction manuals. The type of control boards and accessories must be suitable for the intended use and in compliance with the current safety standards"

## 9) MANUAL OPENING

In case of emergency, for example when the electrical power is disconnected, open the electric lock by means of the appropriate key to release the gate, and open the leaf manually; you may also reach the release knob to facilitate the manoeuvre. In order to get access to the release knob, move the small cap in the direction indicated by the arrow (fig.18) to reveal the lock, insert the key, turn it clockwise by 90° and lift the entire release cover by pulling with the key. The knob must be allowed to turn as far as possible in the direction indicated by the arrows.

**OPEN** to release: the gate can be opened manually with ease.

**CLOSE** to lock: turn the knob clockwise until it is completely locked, and so restore the actuator electrical operation.

## 10) PUSHING FORCE ADJUSTMENT

For safety reasons, proceed as follows in order to get access to the adjustment valves:

- Move the release cover block cap in the direction indicated by the arrow (fig.19) to reveal the lock.
- Insert the key, turn it clockwise by 90° and lift the entire block by pulling with the key. Unscrew the two fixing screws and remove the entire release system.
- The pushing force is adjusted by two valves marked with the writing "**Close**" and "**Open**" respectively, which are used to adjust the closing and opening pushing force (fig.19).

Turn the valves towards the "+" sign to increase the force transmitted; turn the valves towards the "-" sign to reduce the force. To achieve proper antistress safety, the pushing force must be slightly higher than that needed to move the leaf during both closing and opening manoeuvres; the strength, which is measured on the leaf edge, must never exceed the limits set out by the current national standards. **Under no circumstances whatsoever must the by-pass valves be fully closed.** Complete the adjustments and restore the release system, taking care to refit the packing rings and washers. The actuator is not provided with electrical limit switches. Therefore the motors switch off at the end of the operation time set by the control unit. The said operation time must last approximately 2-3 seconds after the moment when the leaves meet the ground stop plates.

## 11) COVERING ELEMENT POSITIONING

Covering element "C" for all models can become left or right-handed by reversing the position of cap "T" (fig.22), taking care to keep the water drainage channel always at the bottom.

## 12) AUTOMATION CHECK

Before the automation device finally becomes operational, scrupulously check the following conditions:

- Check that all components are tightly fixed.
- Check that all control devices (photocells, pneumatic edge etc) operate correctly.
- Check the emergency manoeuvre command.
- Check the opening and closing operations using the control devices provided.
- Check the normal (or personalised) function control logic in the control unit.

## 13) AUTOMATION OPERATION

Since the automation system can be remotely controlled by means of a radio control device or a Start button, all safety devices must be frequently checked in order to ensure their perfect efficiency. In the event of any irregular operation, request immediate assistance from qualified personnel.

**Children must be kept at a safe distance from the automation operation area.**

## 14) CONTROL

Various types of control are provided (manual, radio control, magnetic card access control etc.) depending on the installation requirements and characteristics. (See the specific instructions for the various control systems).

**The installer undertakes to instruct the user about the correct automation operation, and also point out the operations required in case of emergency.**

## 15) MAINTENANCE

Before carrying out any maintenance to the controller, disconnect the system power supply. Periodically check the system for oil leaks.

Topping up should be carried out as follows:

- Remove the release system (see fig.19).
- Keeping the gate closed, top up using the prescribed oil until its level reaches above the piston pipe (fig.20 ref. "P"). To check this, insert a screwdriver through the release cover block fixing hole, so as to reach the piston pipe and make sure it is oiled.
- Refit all the component paying attention to the seals. Check all automation safety devices.

When any operational malfunction is found, and not resolved, disconnect the system power supply and request the assistance of a qualified technician (installer).

**If the power supply cable is damaged, it must be replaced directly by our company or our technical service department or by a technician having similar qualification so as to avoid any risks.** When automation is out of order, activate the manual release knob to allow the manual opening and closing operations to be carried out by means of the electric lock.

## 16) MALFUNCTIONS AND REMEDIES

### 16.1) Faulty operation of the actuator

Using an appropriate instrument, check that the ends of the actuator are supplied with voltage after the opening or closing command is given. If the motor vibrates but does not turn, the causes could be as follows:

- Wrong connection of common wire C (always light blue).
- No connection between the drive capacitor and the two drive terminals.
- If the leaf movement is opposite to what it should be, reverse the motor drive connections in the control unit.

Leaf stops: when the operation time is insufficient, the leaves may not complete their strokes. In that case, slightly increase the operation time setting in the control unit.

### 16.2) Faulty operation of the electrical accessories

All faulty control and safety devices can cause abnormal operation or automation block. If the control unit is provided with a self-diagnosing system, identify the fault. In case of malfunction, it is advisable to disconnect and bridge all the automation devices one by one, if necessary, until the faulty device is identified. After replacing or repairing it, restore all the devices which were previously disconnected or bridged. For all devices installed, refer to their respective instruction manual.

**Warning:** the above operation must be carried out by qualified personnel. During maintenance, the gate operational area must be appropriately indicated and closed off, in order to avoid any danger to persons, animals and property.

**Warnings:** Correct controller operation is only guaranteed when the data specified in this manual are respected. The company cannot be held responsible for any damage caused by failure to observe the standards on safety, installation and good technical practice, as well as the directives specified in the present manual.