

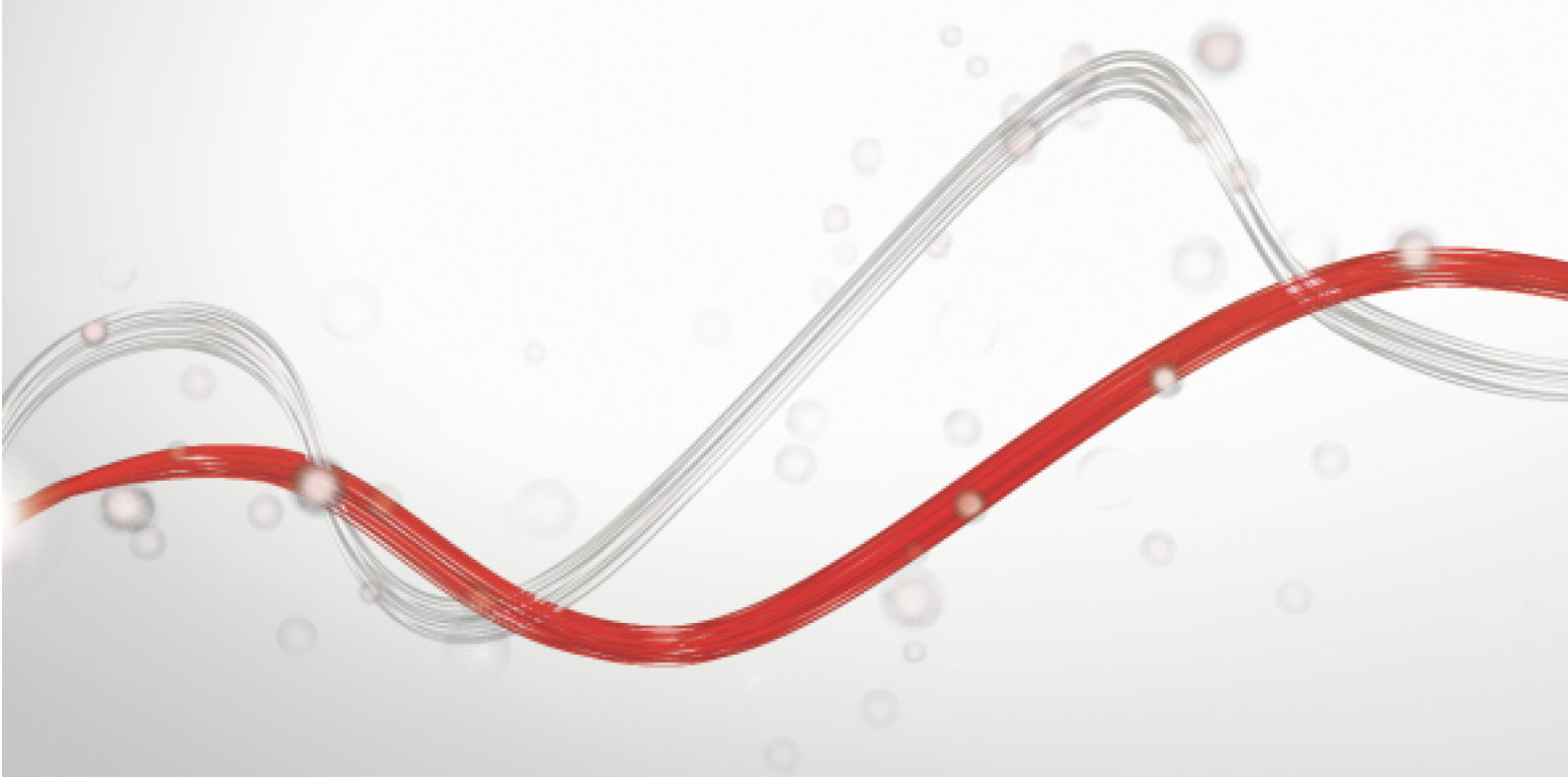

Be ahead

P7 / P4,5





Hydraulic automation systems for swing gates

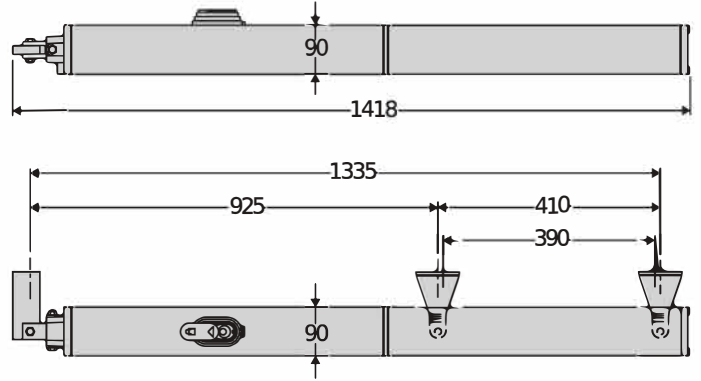

Extremely sturdy and reliable hydraulic operators for industrial and condominium use. They can automate swing gate leaves up to 7m wide and weighing up to 500kg. Smooth, silent gate movements are guaranteed by the extremely high-performance hydraulic system and the closing slowdown. Maximum precision in traction and thrust force control is guaranteed by the by-pass valve system.

Relevant features



The rear articulated brackets and jointed rod make installation simple and reliable in all situations.



The brass release knob, protected with a personal key, facilitates the manual opening of the gate in the event of a power cut.



The closing slowdown guarantees silent, smooth movements on even the biggest gates. Also, the adjustment screw makes it possible to adapt the slowdown intensity to needs of each situation.





Hydraulic automation systems for swing gates

P7 / P4,5

Code	CI	Name	Description
P935061 00001	2600016	P4,5	Reversible hydraulic operator for swing gates up to 4,5 m. 500 kg in weight. Cycle time 28+slowdown s. Useful travel 390 mm. max angle 123 °. Closing slowdown
P935061 00004	2611740	P4,5 WINTER	Reversible hydraulic operator for swing gates up to 4,5 m. 500 kg in weight. Cycle time 28+slowdown s. Useful travel 390 mm. max angle 123 °. Extremely low temperatures
P935061 00003	2611739	P4.5 UL/CSA	Reversible hydraulic operator for swing gates up to 4,5 m. 500 kg in weight. Cycle time 28+slowdown s. Useful travel 390 mm. max angle 123 °. Closing slowdown
P935060 00001	2600516	P7	Reversible hydraulic operator for swing gates up to 7 m. 500 kg in weight. Cycle time 42+slowdown s. Useful travel 390 mm. max angle 123 °. Closing slowdown
P935060 00004	2611736	P7 WINTER	Reversible hydraulic operator for swing gates up to 7 m. 500 kg in weight. Cycle time 42+slowdown s. Useful travel 390 mm. max angle 123 °. Extremely low temperatures
P935060 00003	2611735	P7 UL/CSA	Reversible hydraulic operator for swing gates up to 7 m. 500 kg in weight. Cycle time 42+slowdown s. Useful travel 390 mm. max angle 123 °. Closing slowdown

RIGEL 6 220-230V 50/60HZ: Universal control panel with display for one or two 230V - 650+650W operators



Cp D113833 00002 - CI 2600589 - RIGEL 6 220-230V 50/60HZ - Recommended



- Universal control panel with display for one or two 230V - 650+650W operators
- Application: universal control panel for one or two operators
- Card power supply: 230 V single-phase
- Operators power supply: 230V single-phase
- Main features: removable terminal blocks, programming and diagnostics with display, built-in four-channel receiver, electro lock, electronic torque limiter, electronic deceleration at opening and closing, a separate limit switch inputs for each motor, traffic light management, preheating hydraulic operators, weekly timer, possibility to delete a specific remote control, customization of the 4 radio channels, personalization of the duration of the delayed output, adjustable sensitivity to the obstacle.
- Main functions: automatic re-closing, separate motor working times, stays locked when closed, water hammer, 2/3/4 step logic, partial opening, fast closing, separate opening and closing
- Compatibility: RIGEL 5 - RIGEL 4 - RIGEL 3 - RIGEL N

	P4,5	P4,5 WINTER	P4.5 UL/CSA
Control unit	RIGEL 6	RIGEL 6	RIGEL 6
Board power supply	230 V	230 V	230 V
Motor voltage	230 V	230 V	120 V
Power consumption	250 W	250 W	250 W
Max. width of door/gate wing	4,5 m	4,5 m	4,5 m
Max. weight of door/gate wing	500 kg	500 kg	500 kg
Useful rod stroke	390 mm	390 mm	390 mm
Maximum angle	123 °	123 °	123 °
Cycle time	28+slowdown s	28+slowdown s	28+slowdown s
Type of limit switch	work time	work time	work time
Slowdown	During closing	During closing	During closing
Locking	Solenoid Lock	Solenoid Lock	Solenoid Lock
Release	Reversible	Reversible	Reversible
Impact reaction	Hydraulic clutch	Hydraulic clutch	Hydraulic clutch
Frequency of use	very intensive	very intensive	very intensive
Protection rating	IP55	IP55	IP55









Hydraulic automation systems for swing gates

	P4,5	P4,5 WINTER	P4.5 UL/CSA
Environmental conditions	-10 ÷ 60 °C	-30 ÷ 60 °C	-10 ÷ 60 °C
	P7	P7 WINTER	P7 UL/CSA
Control unit	RIGEL 6	RIGEL 6	RIGEL 6
Board power supply	230 V	230 V	230 V
Motor voltage	230 V	230 V	120 V
Power consumption	250 W	250 W	250 W
Max. width of door/gate wing	7 m	7 m	7 m
Max. weight of door/gate wing	500 kg	500 kg	500 kg
Useful rod stroke	390 mm	390 mm	390 mm
Maximum angle	123 °	123 °	123 °
Cycle time	42+slowdown s	42+slowdown s	42+slowdown s
Type of limit switch	work time	work time	work time
Slowdown	During closing	During closing	During closing
Locking	Solenoid Lock	Solenoid Lock	Solenoid Lock
Release	Reversible	Reversible	Reversible
Impact reaction	Hydraulic clutch	Hydraulic clutch	Hydraulic clutch
Frequency of use	very intensive	very intensive	very intensive
Protection rating	IP55	IP55	IP55
Environmental conditions	-10 ÷ 60 °C	-30 ÷ 60 °C	-10 ÷ 60 °C

VITAL ACCESSORIES

	Cp D114092 00002 - Ci 2601365 ALCOR AC A Control unit with on-board receiver - no display - Standard terminal block		Cp D113680 00002 - Ci 2600108 ALPHA SD Universal control panel with potentiometers for one 230V/500W single-phase operator
--	---	---	--

RECOMMENDED ACCESSORIES

	Cp D610180 - Ci 2600598 CLS Triangular release key l=52 mm		Cp D111013 - Ci 2607261 ME Control board for 12Vac solenoid lock for 230V automation systems
	Cp P111782 - Ci 2601411 COMPACTA A20-180 Pair of photocells adjustable 180° horizontally. 20 metre range. 12-33 VAC/15-35 VDC power supply.		Cp D114094 00002 - Ci 2607540 RADIUS LED AC A RO Flashing light without incorporated antenna for motors with 230 V power supply.
	Cp D114093 00002 - Ci 2607538 RADIUS LED AC A R1 Flashing light with incorporated antenna for motors with 230 V power supply.		new Cp P123032 00001 - Ci 2613516 EBP AC A 230V 50/60HZ 230V vertical electric lock.
	new Cp P123032 00002 - Ci 2613517 EBP AC A 120V 50/60HZ 120V vertical electric lock.		

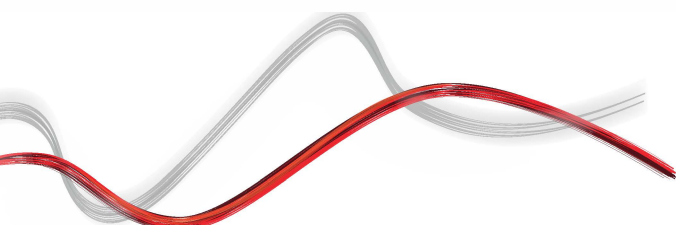



P7 / P4,5



Hydraulic automation systems for swing gates

EasyAXS

EASY CONNECT. EASY ACCESS.



The new connectivity solution which boosts the potential of BFT products and services to make access automations smarter and easier to use for both installers and end users.

1



EASY TO CONNECT



PLUG&PLAY
CONNECTIVITY MODULE
FOR QUICKLY CONNECTING
BFT SOLUTIONS



2

EASY TO SET UP



CONFIGURATION
AND
MANAGEMENT OF
THE MOTOR WITH
THE **EasyAXS app**

3

EASY TO CONTROL



TaHoma app
TO PROVIDE CUSTOMERS
WITH A SMART SOLUTION
FOR ACCESSING THEIR
HOMES





Hydraulic automation systems for swing gates

EASY TO CONNECT

WIFI MODULE



→ 10/15 metres

WIFI MODULE + ANTENNA



→ 20/25 metres

MOBILE MODULE + ANTENNA + SIM



→ ∞



**PLUG&PLAY
INSTALLATION**



**ALWAYS
CONNECTED**



**EVEN MORE
CONNECTIVITY**



**EASY TO SET UP
FOR INSTALLERS**



**EASY TO CONTROL
FOR CUSTOMERS**





Hydraulic automation systems for swing gates



U-LINK 2.0

AN UPDATED VERSION OF
U-LINK TO GIVE YOU EVEN
MORE FUNCTIONALITY



Scalable

You can add as many devices as you want



Intuitive

Easy to install and to use



Functional

Settings can be controlled and firmware updated remotely using dedicated applications



Practical

Works with or without an internet connection



Flexible

It allows you to create groups of interconnected products

U-Link, the exclusive **BFT** technology platform has evolved to offer improved interaction with the latest generation of technological ecosystems. Its ability to interface with all home access automation access devices has been expanded, meaning it is now a very useful tool for installers. It is also a faster communication protocol with increased security for communicating information.

It allows you to save even more time, checking everything very easily and giving you even more peace of mind.



Hydraulic automation systems for swing gates

-SECURITY

A NEW AND EVEN MORE SECURE RADIO PROTOCOL



→ **Secure**
By transmitting
data protected by a
cryptographic key

U-Security is the new technology from **BFT** which incorporates encrypted rolling code thanks to the encryption key which masks the remote control code, meaning that it is impossible to clone a BFT remote control using another brand's model.

The functions of the **Er Ready** system are incorporated and a new procedure is also available for programming remote controls by scanning a QR CODE and using a special app. All products featuring this technology are **REPLAY**, so they can transmit the code to another BFT remote control using a combination of keys.



→ **Easy**
Pairing a remote
control with a receiver
can be done easily
by scanning the QR
code and using the
dedicated app



→ **Universal**
The radio protocol
is also compatible
with the previous
generation of
receivers



INFORMATION REGARDING THE PROTECTION OF THE INDUSTRIAL AND INTELLECTUAL PROPERTY RIGHTS OF BFT. BFT S.p.A. protects its industrial property by depositing trademarks, patents, models and designs. The intellectual property of BFT S.p.A. is protected by copyright law. BFT S.p.A. also protects its know-how by taking measures to protect the technical and commercial information inherent in its company and products. All the products in this catalogue are ORIGINAL BFT MODELS and only BFT S.p.A. is authorised to produce them and market them anywhere in the world. All the commercial names in this catalogue are owned by BFT S.p.A., and only BFT S.p.A. is authorised to use them in relation to the corresponding merchandise category. FALSIFIERS WILL BE PROCEEDED AGAINST IN ACCORDANCE WITH BOTH CIVIL AND CRIMINAL LAW. THESE CONDITIONS NOT ONLY GUARANTEE THE INTELLECTUAL PROPERTY RIGHTS OF BFT, BUT ALSO PROTECT CUSTOMERS BY GUARANTEEING THAT THE PRODUCTS THEY ARE PURCHASING ARE ORIGINAL BFT PRODUCTS RESULTING FROM STUDIES AND DESIGNS WITHIN THE BFT COMPANY.