

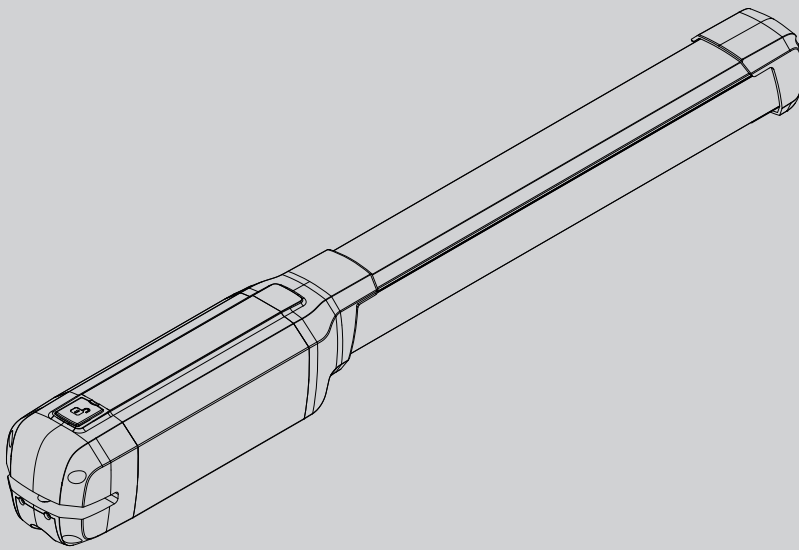

PISTON AUTOMATIONS FOR SWING GATES

AUTOMATIZACIONES A PISTON PARA PORTONES CON BATIENTE



INSTALLATION MANUAL

INSTRUCCIONES DE INSTALACION

PHOBOS BT A25 PHOBOS BT A40

D812868 00100_04.20-04-21



AZIENDA CON
SISTEMA DI GESTIONE
CERTIFICATO DA DNV GL
= ISO 9001 =
= ISO 14001 =

Attention! Read "Warnings" inside carefully! Atención; Leer atentamente las "Advertencias" en el interior!

FIG. Y

With electric lock, Con electrocerradura

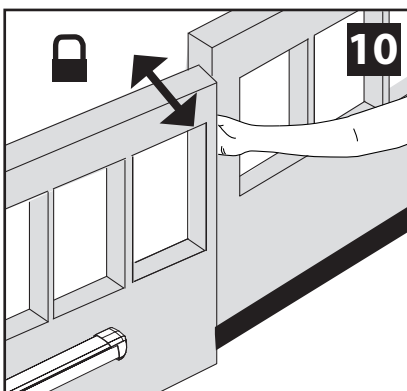
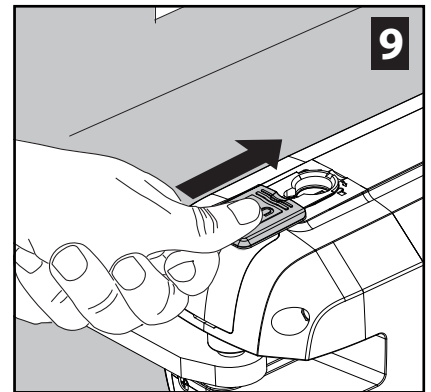
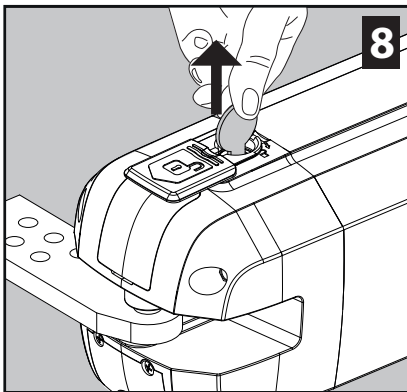
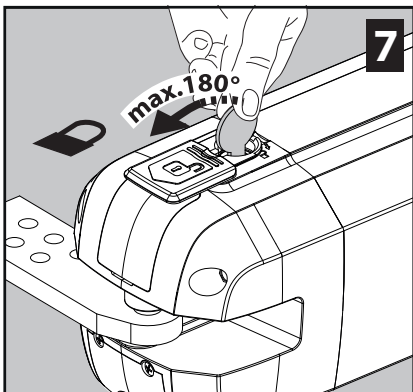
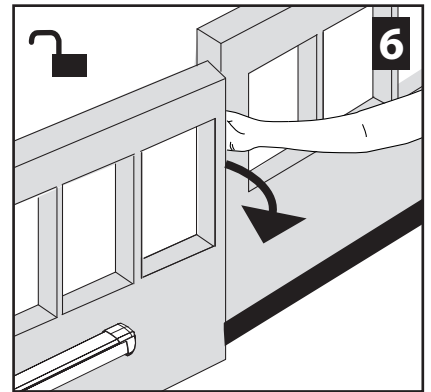
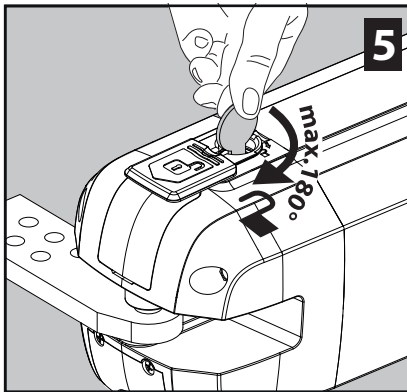
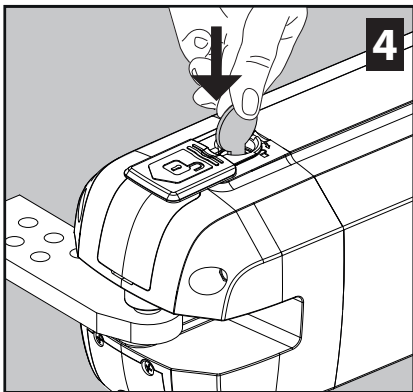
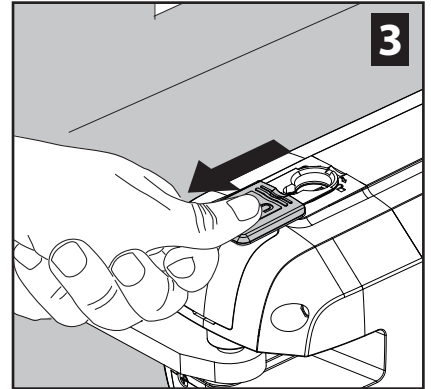
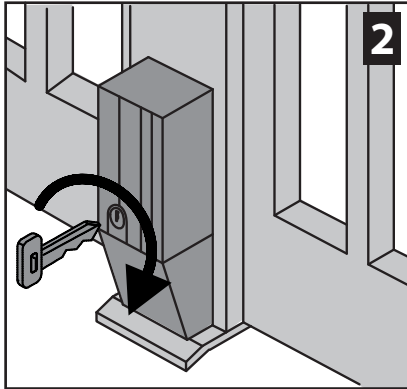
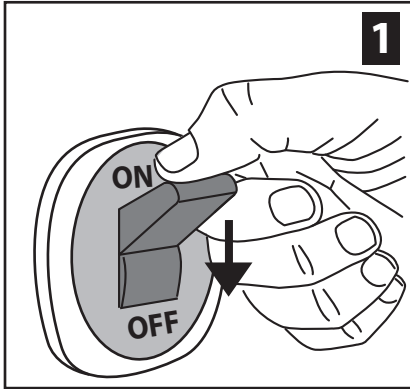
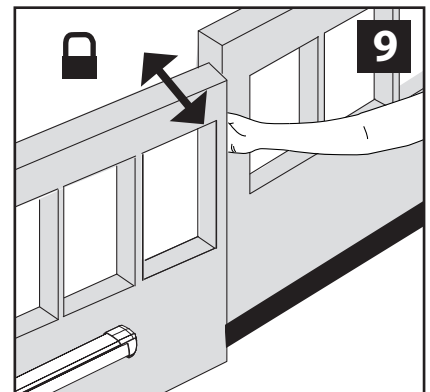
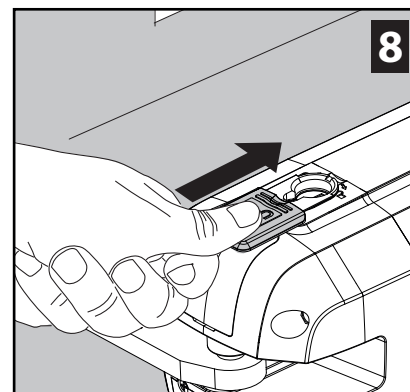
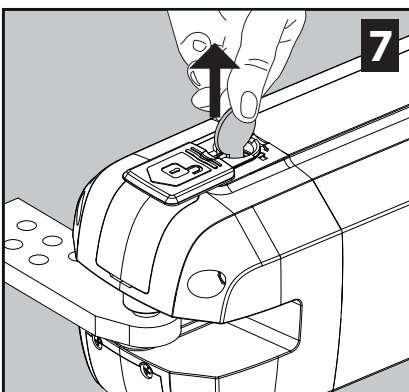
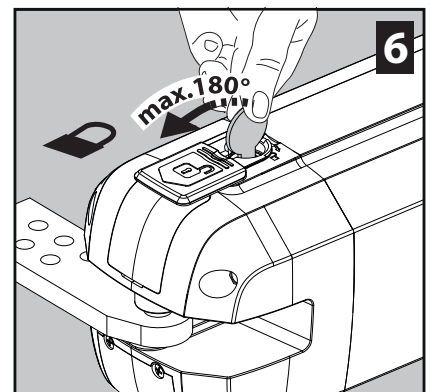
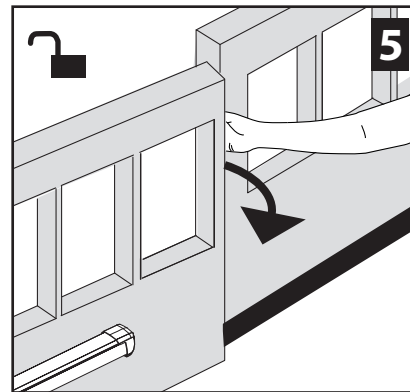
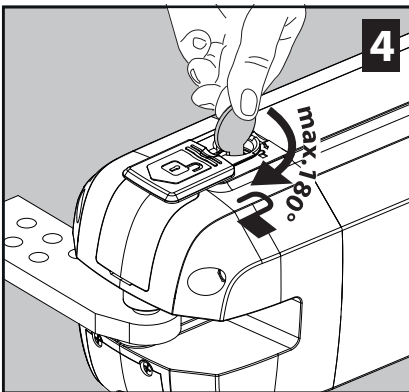
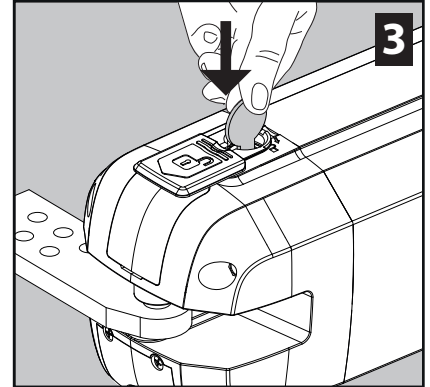
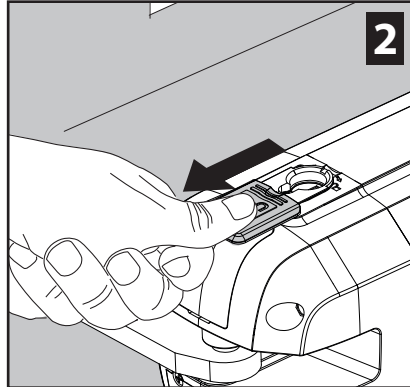
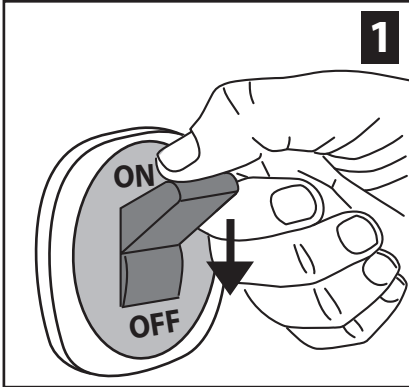
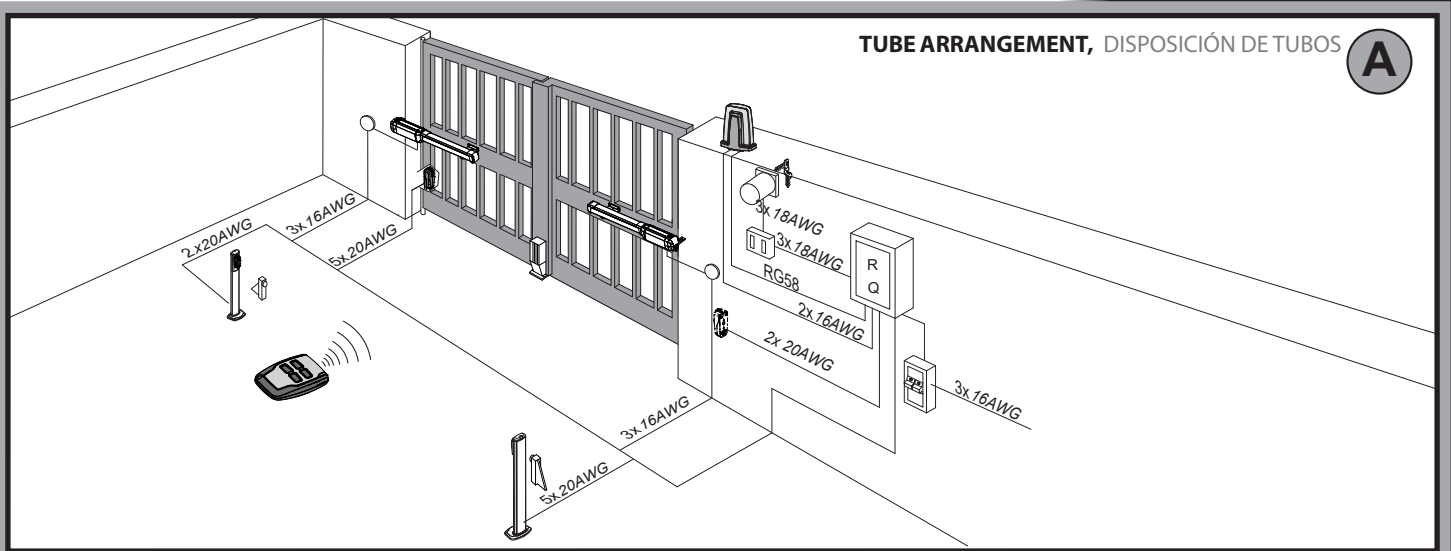

FIG. Y

Without electric lock, Sin electrocerradura



QUICK INSTALLATION-INSTALACIÓN RÁPIDA



INSTALLATION DIAGRAM. ESQUEMA DE INSTALACIÓN.

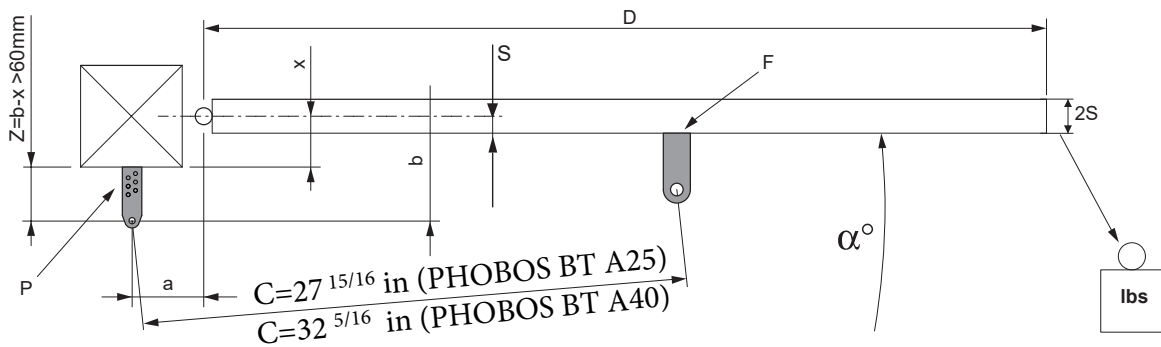

S (in)	PHOBOS BT A25		PHOBOS BT A40	
	275.5 lbs (~ 1250 N)	551 lbs (~ 2500 N)	275.5 lbs (~ 1250 N)	551 lbs (~ 2500 N)
	b (in)		b (in)	
13/16	3 15/16 ÷ 4 3/4	5 1/8 ÷ 8 1/4	5 1/8 ÷ 6 5/16	6 11/16 ÷ 10 1/4
1 3/16	3 15/16 ÷ 5 1/8	5 1/2 ÷ 8 1/4	5 1/8 ÷ 6 11/16	7 1/16 ÷ 10 1/4
1 9/16	3 15/16 ÷ 5 1/2	5 7/8 ÷ 8 1/4	5 1/8 ÷ 7 1/16	7 1/2 ÷ 10 1/4
1 15/16	3 15/16 ÷ 5 7/8	6 5/16 ÷ 8 1/4	5 1/8 ÷ 7 1/2	7 7/8 ÷ 10 1/4

2 PHOBOS BT A25

b	a	3 15/16	4 5/16	4 3/4	5 1/8	5 1/2	5 7/8	6 5/16	6 11/16
3 15/16					114	116	108	102	97
4 5/16					112	108	103	98	95
4 3/4					111	105	99	95	
5 1/8				107	105	100	95	92	
5 1/2				105	100	95	92		
5 7/8		105	100	95	92				
6 5/16		101	95	92	89				
6 11/16	101	93	91	89					
7 1/16	92	90	88						
7 1/2	90	87							
7 7/8	87								α°

3 PHOBOS BT A40

b	a	3 15/16	4 5/16	4 3/4	5 1/8	5 1/2	5 7/8	6 5/16	6 11/16	7 1/16	7 1/2	7 7/8	8 1/4	8 11/16	9 1/16
5 1/8		100	104	107	110	113	116	119	121	124	123	114	109	104	101
5 1/2		100	103	106	109	112	115	118	120	122	116	110	107	102	98
5 7/8		99	102	105	108	111	114	117	119	120	112	106	102	98	95
6 5/16		98	101	105	107	110	113	115	116	114	109	103	99	96	
6 11/16		97	100	104	107	109	112	114	113	109	105	100	96	93	
7 1/16		97	100	103	106	108	111	113	109	105	100	97	93		
7 1/2		97	100	102	105	107	109	112	106	101	96	93			
7 7/8		97	99	101	104	106	106	106	100	97	93				
8 1/4		96	98	101	103	106	104	103	97	92					
8 11/16		96	98	101	103	105	101	97	93						
9 1/16		96	98	101	103	105	97	93							
9 7/16		95	97	99	99	96	92								
9 13/16		95	97	97	95	91									
10 1/4		95	97	95	91										α°

FASTENING OF FITTINGS TO PILLAR. ANCLAJES DE LAS FIJACIONES AL PILAR.

C

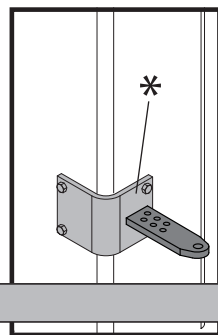
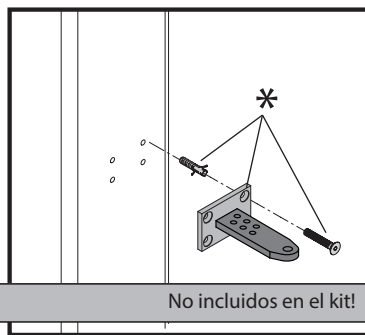
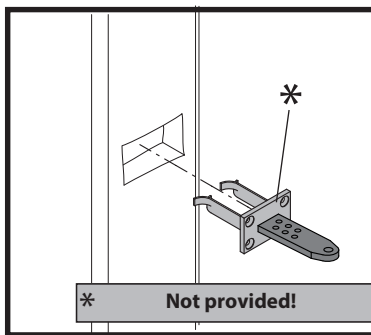
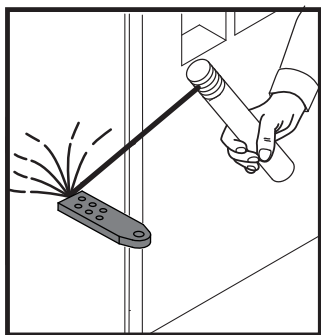

* **Not provided!**

No incluidos en el kit!

POWER CABLE. CABLE DE ALIMENTACIÓN.

D

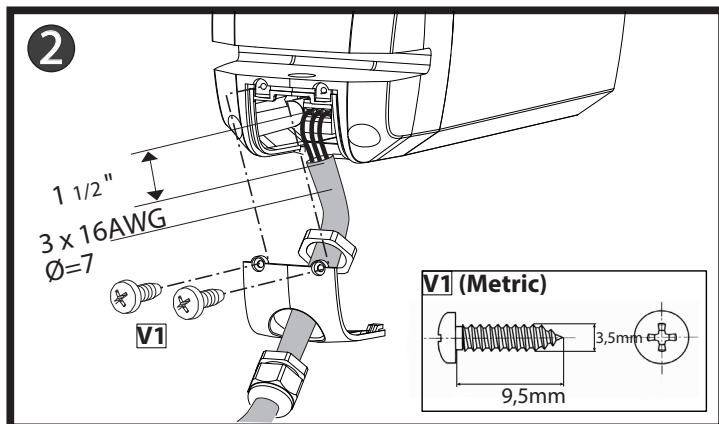
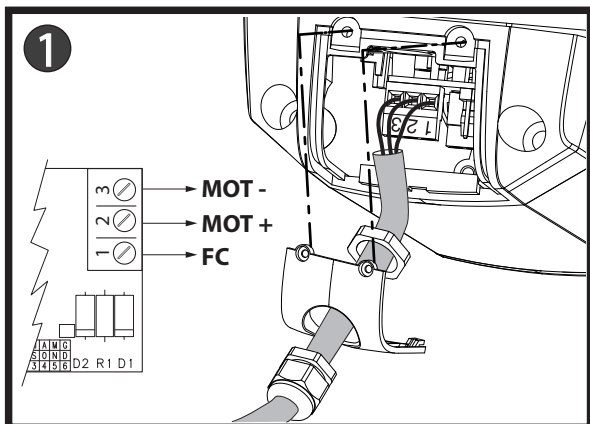

ATTACHING MOTOR TO FASTENING ON PILLAR. FIJACIÓN MOTOR EN ANCLAJE AL PILAR.

FIJACIÓN MOTOR EN ANCLAJE AL PILAR.

E

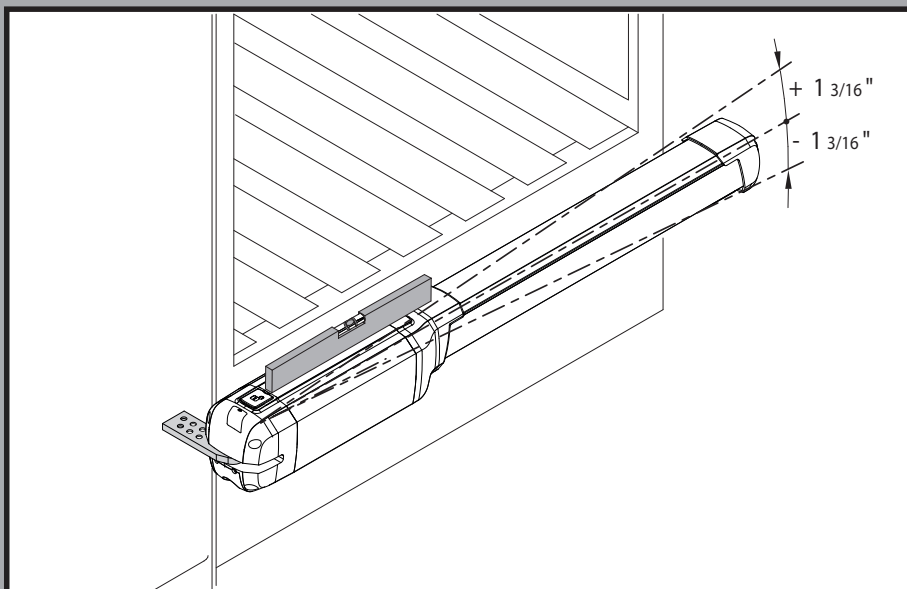
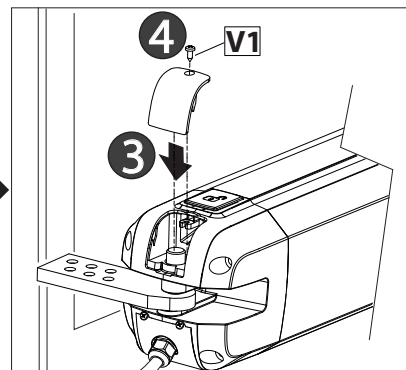
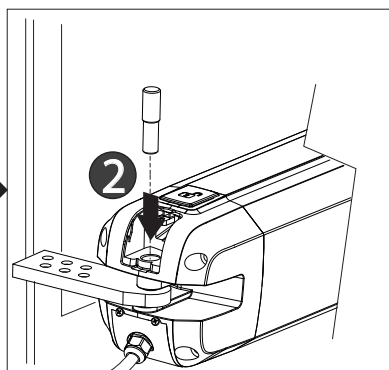
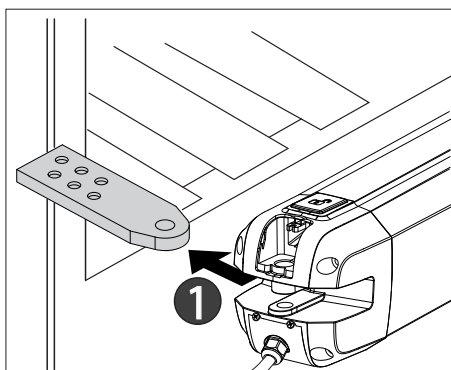

MAXIMUM TILT. INCLINACIÓN MÁXIMA.

F

ENGLISH

ESPAÑOL

CORRECT INSTALLATION. INSTALACIÓN CORRECTA.

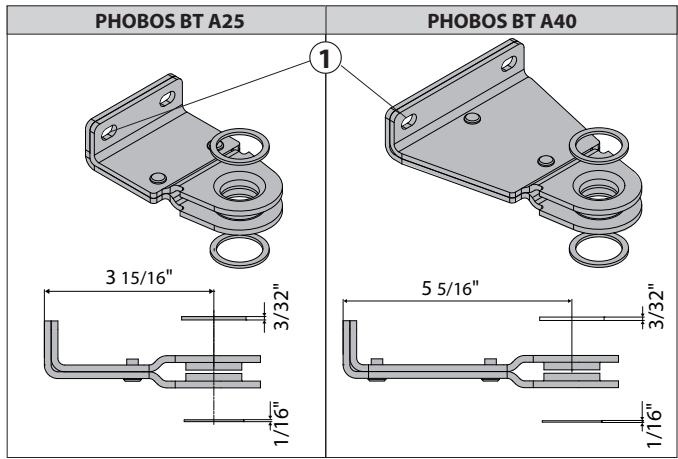
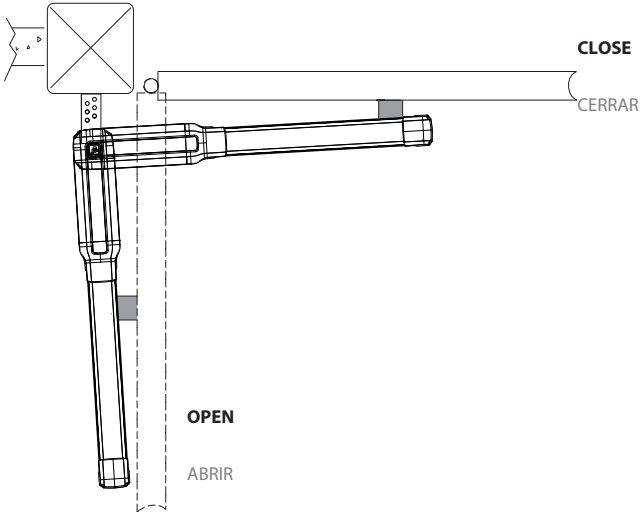

G

FASTENING OF FITTINGS TO LEAF. ANCLAJES DE LAS FIJACIONES A LA HOJA.

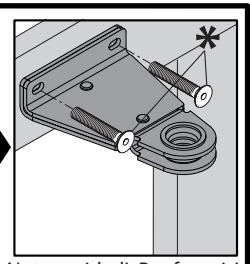
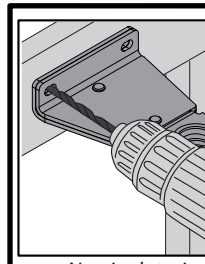
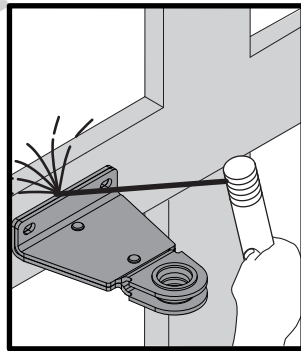
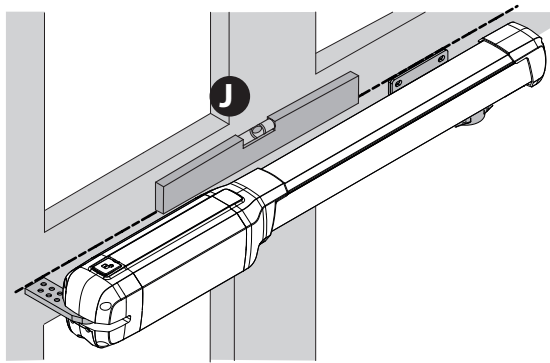

* Non in dotazione! Not provided! Pas fournis!
Nicht mitgeliefert! No incluidos en el kit!
Niet meegeleverd!

H

OPERATOR ATTACHMENT ON DOOR, FIJACIÓN OPERADOR EN LA HOJA

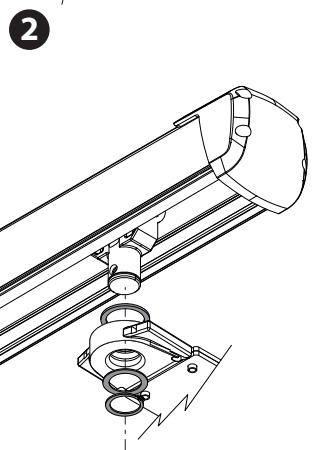
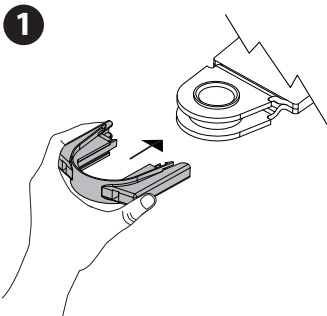

CLOSING LIMIT DEVICE ADJUSTMENT, REGULACIÓN DEL FIN DE CARRERA DE CIERRE

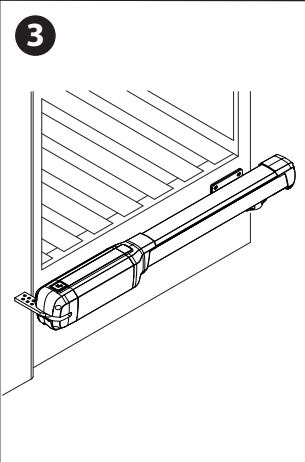
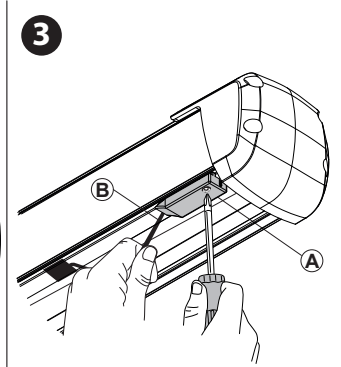
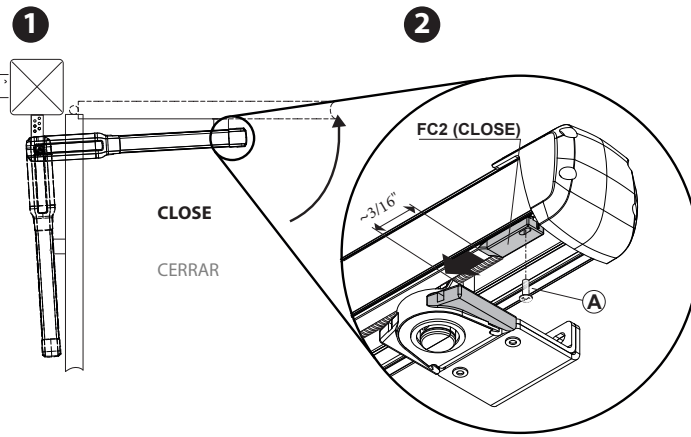

OPENING LIMIT DEVICE ADJUSTMENT, REGULACIÓN DEL FIN DE CARRERA DE APERTURA.

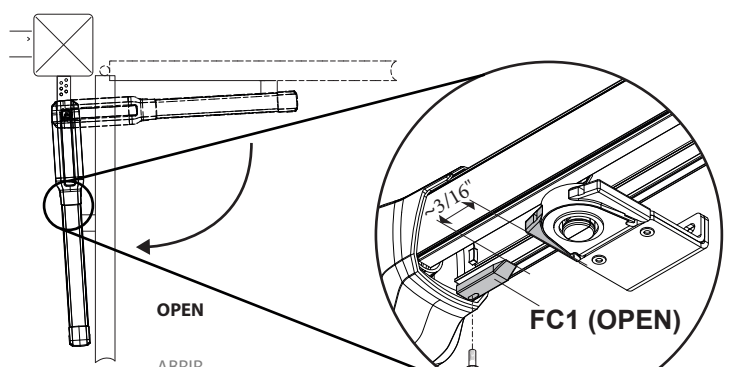

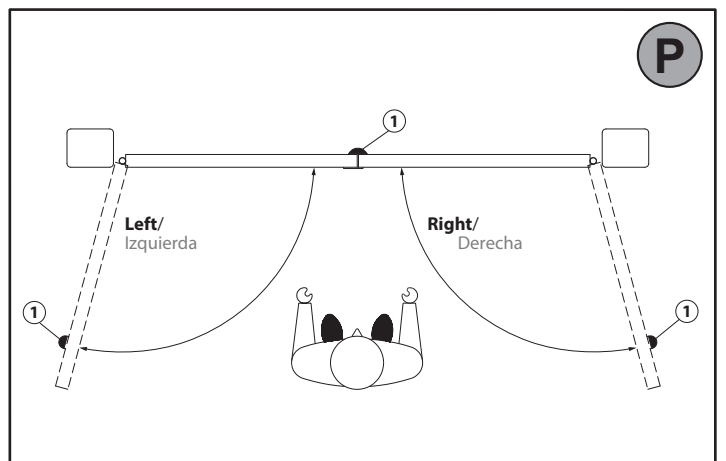
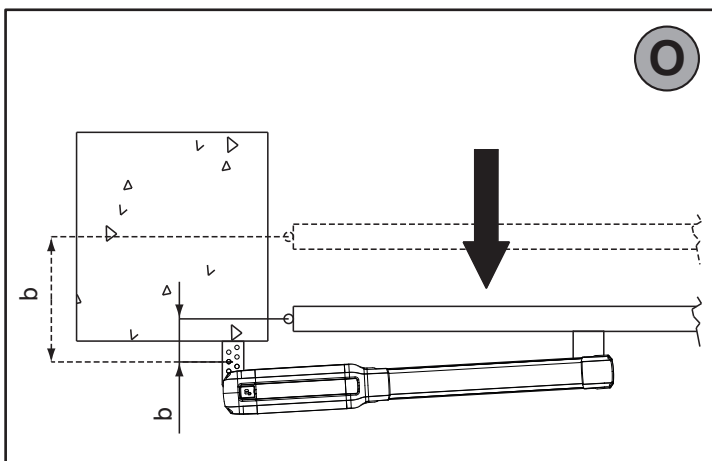
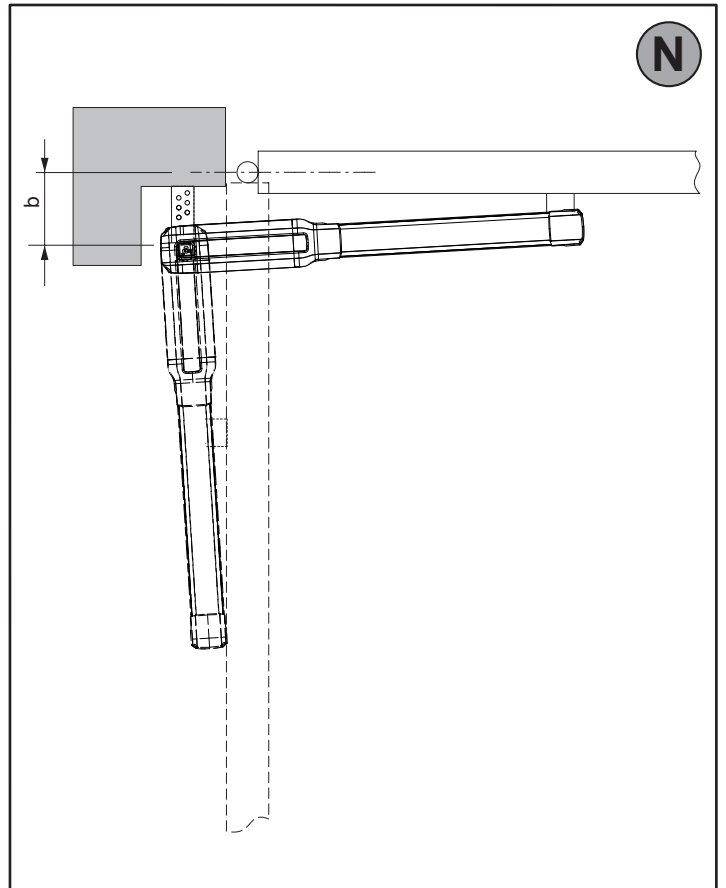
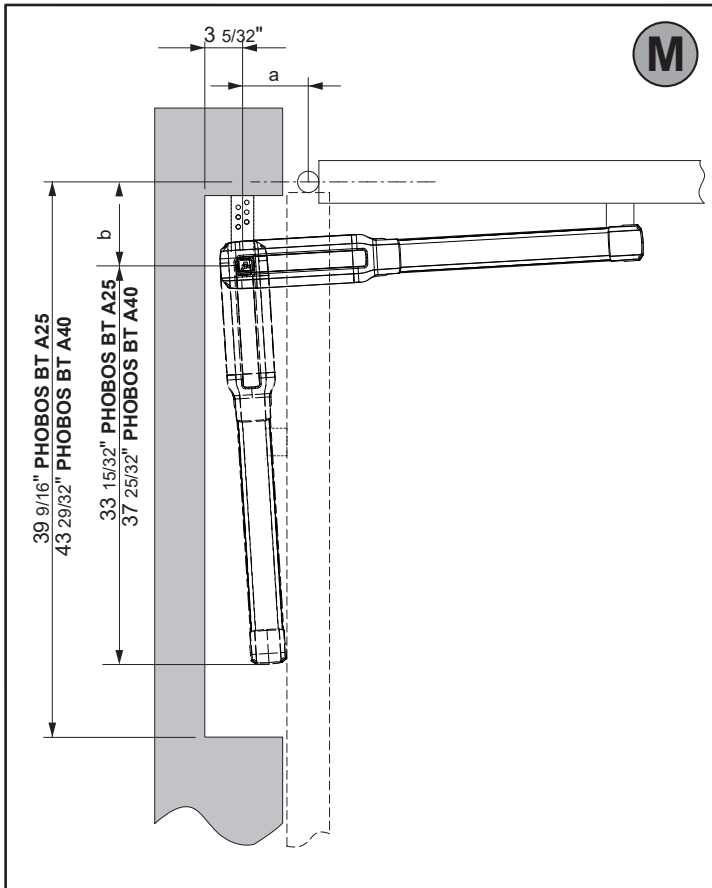
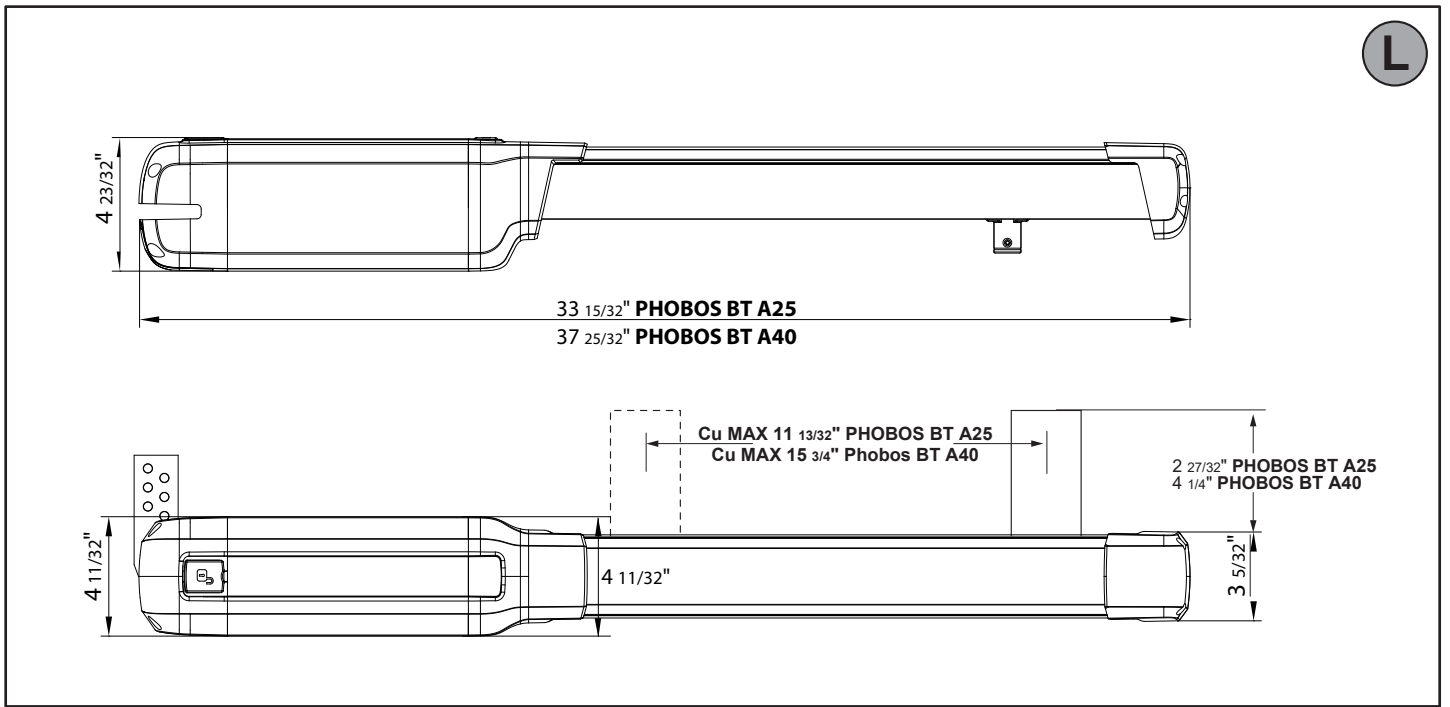

2) GENERAL INFORMATION

Electromechanical operator designed to automate residential-type gates. The gearmotor keeps the gate locked on closing and on opening, without needing an electric lock for leaves up to 3 m long. The operator is provided with an electronic torque limiter. It must be controlled by an electronic control panel provided with torque setting. The end-of-stroke operation is controlled by two magnetic limit devices. The operator is provided with an obstacle detection system complying with EN12453 and EN 12445 standards.

The following optional accessories are available on request:

- Buffer battery kit mod. BT BAT

Allows operation of the automation even when there is no mains power supply for a short period of time.

3) TECHNICAL SPECIFICATIONS

Power supply	24V $\overline{\text{---}}$
Max. Absorbed power	40 W
Absorbed current	1,5 A
Push and pull force	2500 N (~550 lbs)
Stem speed	19/32"/s approx.
Impact reaction	Torque limiter aboard control board
Limit devices	Magnetic, incorporated and adjustable
Manual manoeuvre	Personalized release key
Environmental conditions	- 04°F to +131°F
Type of use	intensive
Maximum leaf length without electric lock	6' 6 3/4" PHOBOS BT A25 9' 10 1/8" PHOBOS BT A40
Maximum leaf length with electric lock	8' 2 7/16" PHOBOS BT A25 13' 1 15/32" PHOBOS BT A40
Max. leaf weight	4000 N (~882 lbs) PHOBOS BT A25 5000 N (~1,102 lbs) PHOBOS BT A40
Protection level	IP X4
Controller weight	50N (~11 lbs) PHOBOS BT A25 77N (~17 lbs) PHOBOS BT A40
Dimensions	See Fig. L
Lubrication	permanent grease
Sound pressure	LpA<70dbA

MAXIMUM LENGTH/DOOR WEIGHT

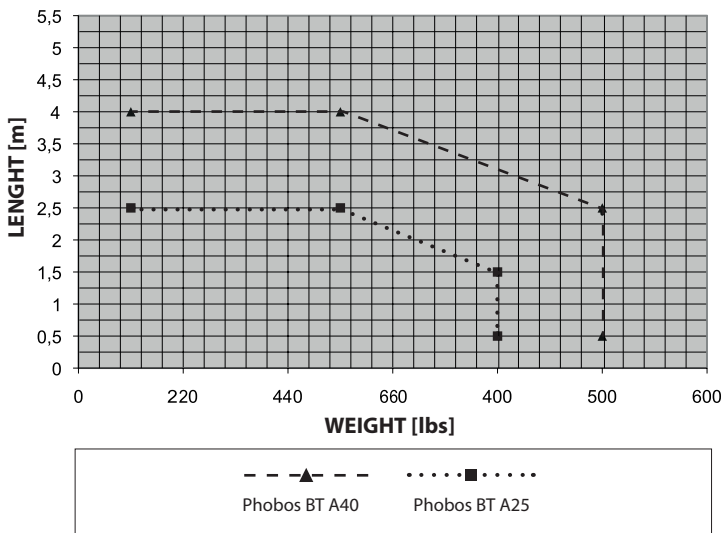

4) TUBE ARRANGEMENT Fig. A

Install the electrical system referring to the standards in force for electrical systems CEI 64-8, IEC 364, harmonization document HD 384 and other national standards.

5) INSTALLATION DIAGRAM Fig. B

- P rear bracket fastening to pillar
- F front fork fastening leaf
- a-b distances for determining bracket "P" fastening point
- C value of fastening centre-to-centre distance
- D gate length
- X distance from gate axis to corner of pillar
- S half door thickness
- Z value always greater than 45 mm (b - X)

- kg max. weight of leaf
- α° leaf opening angle

6) PILLAR FASTENINGS INSTALLATION DISTANCES Fig. B Rif. 2-3

6.1) How to read the installation distance tables

Select "a" and "b" according to the angle in degrees α° that the gate has to open. The optimum "a" and "b" values for 92° opening at constant speed are highlighted. If there is too large a difference between "a" and "b", the leaf will not travel smoothly and the pushing or pulling force will fluctuate during its stroke. To respect the opening speed and ensure the controller operates correctly, it is best to keep the difference between "a" and "b" as low as possible. The table has been worked out for a 40 mm (PHOBOS BT A40), 20 mm (PHOBOS BT A25) thick medium-size gate. Always check that there is no possible collision between the gate and the operator.

7) FASTENING OF FITTINGS TO PILLAR Fig. C

8) POWER CABLE Fig. D

The board power supply cable must be of the H05RN-F type or equivalent. The equivalent cable must guarantee:

- permanent outside use
- maximum temperature on the cable surface of $+50^\circ\text{C}$
- minimum temperature of -25°C

If the motor vibrates but does not rotate, the problem may be:

- Incorrect wiring (see wiring diagram)
- If the leaf moves in the wrong direction, swap over the motor's start connections in the control unit. The first command following a mains power outage should be open STOP LEAVES.

9) ATTACHING MOTOR TO FASTENING ON PILLAR Fig. E

10) MAXIMUM TILT Fig. F

11) CORRECT INSTALLATION Fig. G

Correct installation entails maintaining a rod stroke margin of approx. 5-10 mm to avoid possible trouble with operation.

IMPORTANT: THE FRONT BRACKET MUST BE FITTED WITH THE SLOTS FACING UP (FIG.G RIF.1).

12) FASTENING OF FITTINGS TO LEAF Fig. H

IMPORTANT: the front bracket must be fitted with the slots facing up (Fig. G Ref. 1). Line up the front and rear brackets as shown in Fig. H Ref. J.

13) OPERATOR ATTACHMENT ON DOOR Fig. I

14) CLOSING LIMIT DEVICE ADJUSTMENT Fig. J

ATTENTION! To avoid braking the limit switch cable, tighten screw A keeping the wire B well tightened (as shown in Fig. J Ref. 3).

15) OPENING LIMIT DEVICE ADJUSTMENT (Fig. K)

16) DIMENSIONS Fig. L

17) TIPS FOR SPECIAL INSTALLATIONS Fig. M, N, O.

With the leaf fully open, create a recess to accommodate the operator. **Fig. M** gives the minimum dimensions of the recess for the various **PHOBOS BT A25 - PHOBOS BT A40** models.

If distance "b" is greater than the values given in the installation tables:

- create a recess in the pillar **Fig. N**
- move the leaf so that it is flush with the pillar **Fig. O**.

18) LEAF STOPS AT GROUND LEVEL

For the actuator to work properly, it is advisable to use stops "Fig. P Rif. 1" to stop the leaves both when they are open and closed, as illustrated in **Fig. P**. The leaf stops must prevent the actuator rod from reaching the end of its travel.

19) MANUAL OPENING (See USER GUIDE -FIG.Y-).

20) ELECTRIC LOCK

WARNING: In the case of leaves longer than 3m, it is indispensable to install a solenoid latch.

For electric lock connection, the optional board is required (refer to the appropriate instruction).

2) GENERALIDADES

Automatismo electromecánico proyectado para automatizar cancelas de tipo residencial. El motorreductor mantiene el bloqueo de cierre y apertura sin necesidad de electrocerradura en hojas con una longitud máxima de 3 m. El servomotor está provisto de limitador del par electrónico. Debe ser gobernado por un cuadro de mandos electrónico dotado de regulación del par. El funcionamiento de fin de carrera está regulado por dos fines de carrera magnéticos.

El servomotor está provisto de un sistema de detección de obstáculos, de conformidad con las normas EN12453 y EN 12445

Están disponibles los siguientes accesorios opcionales:

- Kit batería tampón mod. BT BAT

Permite el funcionamiento del automatismo en caso de que falte, por un breve período, el suministro de corriente.

3) DATOS TECNICOS

Alimentación	24V
Potencia absorbida	40 W
Corriente absorbida	1,5 A
Fuerza de empuje y tracción	2500 N (~250 kg)
Velocidad vástago	15 mm/s approx.
Reacción al impacto	Limitador de par integrado en el cuadro de mandos
Fines de carrera	magnéticos, incorporados y regulables
Maniobra manual	Llave personalizada de desbloqueo
Condiciones ambientales	De -20 °C a +55 °C
Tipo de uso	intensivo
Longitud máxima hoja sin electrocerradura	2 m PHOBOS BT A25 3 m PHOBOS BT A40
Longitud máxima hoja con electrocerradura	2,5 m PHOBOS BT A25 4 m PHOBOS BT A40
Peso máximo hoja	50N (~5kg) PHOBOS BT A25 77N (~7,7kg) PHOBOS BT A40
Grado de protección	IP X4
Peso operador	50N (~5kg) PHOBOS BT A25 77N (~7,7kg) PHOBOS BT A40
Dimensiones	Véase Fig. L
Lubricación	Grasa permanente
Presión acústica	LpA<70dbA

LONGITUD MÁXIMA/PESO HOJA

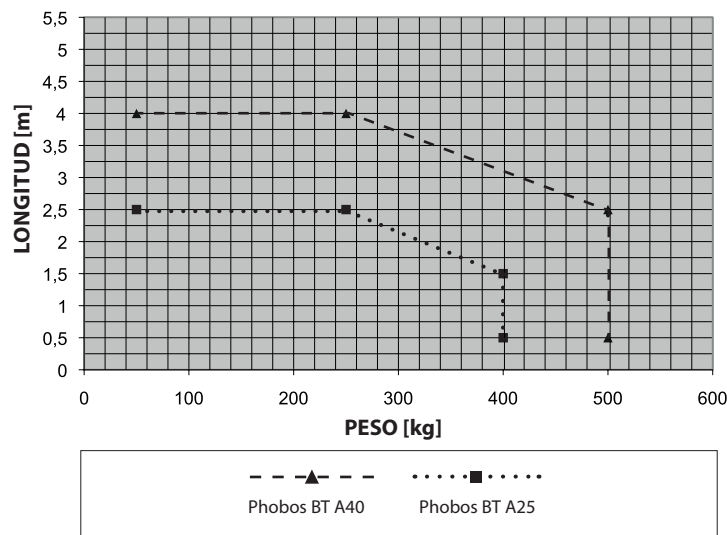

4) DISPOSICIÓN DE TUBOS Fig. A

Realizar la instalación eléctrica remitiéndose a las normas vigentes para las instalaciones eléctricas CEI 64-8, IEC364, armonización HD384 y otras normas nacionales.

5) ESQUEMA DE INSTALACIÓN Fig. B

- P abrazadera posterior de fijación al pilar
- F horquilla anterior de fijación a la hoja
- a-b cotas para determinar el punto de fijación de la abrazadera "P"
- C valor de la distancia entre ejes de fijación
- D longitud de la cancela
- X distancia del eje de la cancela al canto del pilar
- S mitad espesor hoja
- Z valor siempre superior a 45 mm (b - X)

12 - PHOBOS BT A25 - PHOBOS BT A40

- kg peso máx de la hoja
- α° ángulo de apertura de la hoja

6) COTAS DE INSTALACIÓN DE ANCLAJES AL PILAR Fig. B Rif. 2-3

6.1) Cómo interpretar la tabla de las medidas de instalación

De la tabla se pueden escoger valores de "a" y "b" en función de los grados α° de apertura que se deseen obtener. Se evidencian los valores de "a" y de "b" ideales para una apertura de 92° a velocidad constante.

Si se utilizan valores de "a" y "b" demasiado diferentes entre sí, el movimiento de la hoja no es constante y la fuerza de tracción o empuje varía durante el movimiento.

Para respetar la velocidad de apertura y garantizar un buen funcionamiento del operador, es conveniente que los valores "a" y "b" sean poco diferentes entre sí. La tabla se ha elaborado para una cancela mediana de 40 mm (PHOBOS BT A40), 20 mm (PHOBOS BT A25) de espesor. Hay que controlar siempre que no se produzcan colisiones entre la cancela y el servomotor.

7) ANCLAJES DE LAS FIJACIONES AL PILAR Fig. C

8) CABLE DE ALIMENTACIÓN Fig. D

El cable de alimentación de la tarjeta debe ser de tipo H05RN-F o equivalente. El cable equivalente debe garantizar:

- una utilización exterior permanente,
- una temperatura máxima en la superficie del cable de +50° C,
- una temperatura mínima de -25° C.

Si el motor vibra pero no gira, puede deberse a que:

- La conexión de los cables es incorrecta (controlar el esquema de conexión).
- Si el movimiento de la hoja es contrario al que debería ser, invertir las conexiones de marcha del motor en la centralita.

El primer mando tras una interrupción de red debe ser de apertura PARADAS HOJAS.

9) FIJACIÓN MOTOR EN ANCLAJE AL PILAR Fig. E

10) INCLINACIÓN MÁXIMA Fig. F

11) INSTALACIÓN CORRECTA Fig. G

Una instalación correcta prevé mantener un margen de carrera del vástago de aproximadamente 5-10 mm; esto evita posibles anomalías de funcionamiento.

¡IMPORTANTE: EL MONTAJE DE LA ABRAZADERA DELANTERA SE DEBE REALIZAR CON LAS RANURAS HACIA ARRIBA (FIG. G REF. 1).

12) ANCLAJES DE LAS FIJACIONES A LA HOJA Fig. H

¡IMPORTANTE: el montaje de la abrazadera delantera se debe realizar con las ranuras hacia arriba (Fig. G Ref. 1). Alinear las abrazaderas delantera y trasera como se muestra en la Fig. H Ref. J.

13) FIJACIÓN OPERADOR EN LA HOJA Fig. I

14) REGULACIÓN DEL FIN DE CARRERA DE CIERRE Fig. J

¡ATENCIÓN! Para evitar la rotura del cable del fin de carrera, hay que fijar el tornillo A manteniendo tenso el hilo B (como se representa en la Fig. J Rif. 3).

15) REGULACIÓN DEL FIN DE CARRERA DE APERTURA Fig. K

16) DIMENSIONES FIG. L

17) MEDIDAS PARA INSTALACIONES ESPECIALES Fig. M, N, O.

Es necesario realizar una cavidad para alojar el operador cuando la hoja está completamente abierta.

En la Fig. M se indican las medidas que tiene que tener la cavidad para los diversos modelos **PHOBOS BT A25 - PHOBOS BT A40**.

Si la cota "b" resulta superior a los valores indicados en las tablas de instalación:

- realizar una cavidad en el pilar Fig. N.
- acercar la hoja al filo del pilar Fig. O.

18) TOPES DE LAS HOJAS EN EL SUELO

Para el correcto funcionamiento del accionador se recomienda utilizar topes "Fig. P Rif. 1" tanto para la fase de apertura como para la de cierre, como se indica en la Fig. P.

Los topes de las hojas deben evitar que el vástago del accionador llegue hasta el final de la carrera.

19) APERTURA MANUAL (Véase MANUAL DE USO -FIG.Y-).

20) ELECTROCERRADURA

¡ATENCIÓN: En el caso de hojas con una longitud superior a 3m, resulta indispensable la instalación de una electrocerradura de resorte. Para la conexión de la electrocerradura, es necesaria la tarjeta opcional (consulte las instrucciones específicas).



www.bft-automation.com

BFT Spa

Via Lago di Vico, 44 ITALY
36015 Schio (VI)
T +39 0445 69 65 11
F +39 0445 69 65 22

SPAIN

BFT GROUP ITALIBERICA DE AUTOMATISMOS SL
Camí de Can Bassa, 6, 08401 Granollers, Barcelona, Spagna

FRANCE

AUTOMATISMES BFT FRANCE SAS
50 rue jean zay
69800 Saint-Priest, Francia

GERMANY

BFT ANTRIEBSSYSTEME GMBH
Faber-Castell-Straße 29, 90522 Oberasbach, Germania

UNITED KINGDOM

BFT AUTOMATION UK LTD
Unit C2-C3 The Embankment Business Park, Vale Road Heaton Mersey Stockport Cheshire SK4 3GL United Kingdom

BFT AUTOMATION (SOUTH) LTD
Enterprise House Murdock Road, Dorcan, Swindon, England, SN3 5HY

PORTUGAL

BFT PORTUGAL SA
Urb. Pedrulha lote 9 - Apartado 8123, 3025-248 Coimbra Portugal

POLAND

BFT POLSKA SP ZOO
Marecka 49, 05-220 Zielonka, Polonia

IRELAND

BFT AUTOMATION IRELAND
Unit D3 City Link Business Park, Old Naas Road, Dublin

CROATIA

BFT ADRIA DOO
Obrovac 39, 51218, Dražice, Croazia

CZECH REPUBLIC

BFT CZ SRO
Ustecka 533/9, 184 00 Praha 8, Czech

TURKEY

BFT OTOMASYON KAPI
Şerifali Mahallesi, no, 34775 Ümraniye/İstanbul, Turchia

U.S.A.

BFT AMERICAS INC.
1200 S.W. 35th Avenue Suite B Boynton Beach FL 33426

AUSTRALIA

BFT AUTOMATION AUSTRALIA PTY
29 Bentley St, Wetherill Park NSW 2164, Australia

EMIRATES

BFT MIDDLEEAST FZCO
FZS2 AA01 -PO BOX 262200, Jebel Ali Free Zone South Zone 2, Dubai - United Arab

NEW ZEALAND

BFT AUTOMATION NEW ZEALAND
224/A Bush Road, Rosedale, Auckland, New Zealand