

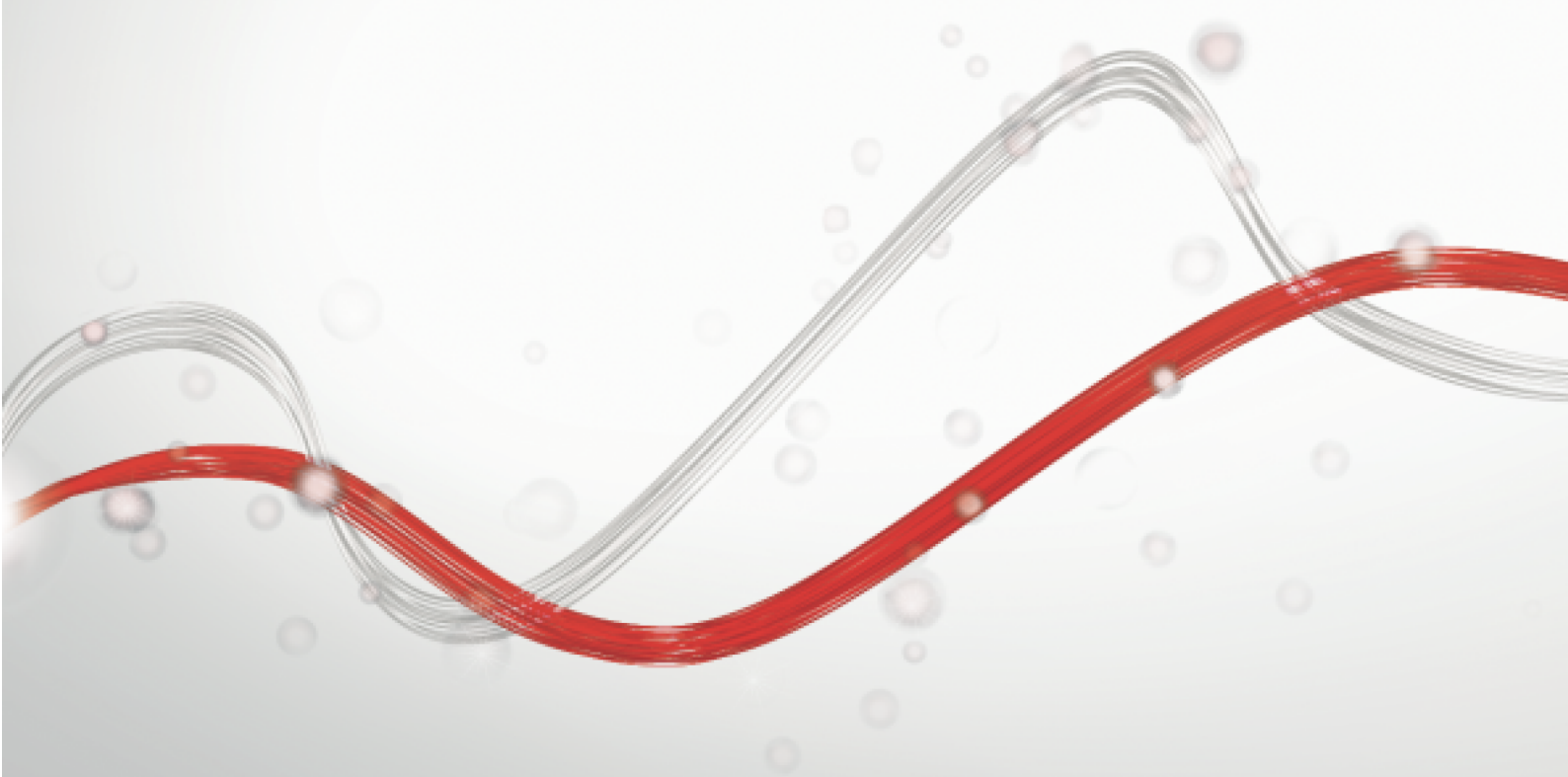

Be ahead

# RANCH B





## Parking and traffic bollards

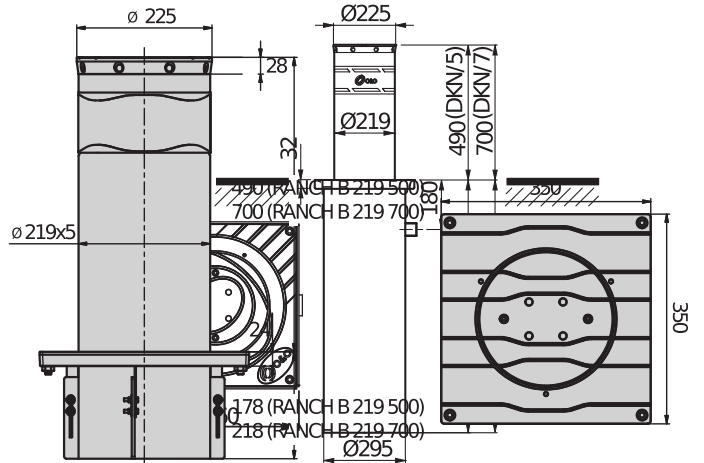
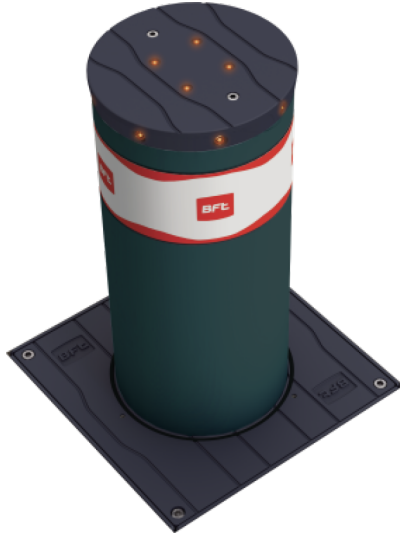

Fixed bollards used for preventing access for long periods. Bolted to the ground, their purpose is to block an access point or a road. They can integrate the use of automatic or semi-automatic bollards.



## Parking and traffic bollards

### RANCH B

Code	Name	Description
P970081 00001	RANCH B 219/500	Fixed bollard, shaft diameter 219 mm and height 490 mm. Painted stainless steel version, RAL 7015
P970081 00101	RANCH B 219/500 - RAL	Fixed bollard, shaft diameter 219 mm and height 490 mm. Painted steel version, RAL colour to order
P970081 00003	RANCH B 219/500 I	Fixed bollard, shaft diameter 219 mm and height 490 mm. Stainless steel version
P970081 00002	RANCH B 219/500 L	Fixed bollard, shaft diameter 219 mm and height 490 mm. Painted steel version, RAL 7015, with LED lights cap
P970081 00102	RANCH B 219/500 L - RAL	Fixed bollard, shaft diameter 219 mm and height 490 mm. Painted steel version, with LED lights cap, RAL colour to order
P970081 00004	RANCH B 219/500 LI	Fixed bollard, shaft diameter 219 mm and height 490 mm. Stainless steel version, with LED lights cap
P970082 00001	RANCH B 219/700	Fixed bollard, shaft diameter 219 mm and height 700 mm. Painted stainless steel version, RAL 7015
P970082 00101	RANCH B 219/700 - RAL	Fixed bollard, shaft diameter 219 mm and height 700 mm. Painted steel version, RAL colour to order
P970082 00003	RANCH B 219/700 I	Fixed bollard, shaft diameter 219 mm and height 700 mm. Stainless steel version
P970082 00002	RANCH B 219/700 L	Fixed bollard, shaft diameter 219 mm and height 700 mm. Painted steel version, RAL 7015, with LED lights cap
P970082 00102	RANCH B 219/700 L - RAL	Fixed bollard, shaft diameter 219 mm and height 700 mm. Painted steel version, with LED lights cap, RAL colour to order.
P970082 00004	RANCH B 219/700 LI	Fixed bollard, shaft diameter 219 mm and height 700 mm. Stainless steel version, with LED lights cap

	RANCH B 219/500	RANCH B 219/500 - RAL	RANCH B 219/500 I	RANCH B 219/500 L	RANCH B 219/500 L - RAL	RANCH B 219/500 LI
Operator type	Fixed bollards	Fixed bollards	Fixed bollards	Fixed bollards	Fixed bollards	Fixed bollards
Rod height	490 mm	490 mm	490 mm	490 mm	490 mm	490 mm
Rod diameter	219 mm	219 mm	219 mm	219 mm	219 mm	219 mm
Rod thickness	5 mm	5 mm	5 mm	5 mm	5 mm	5 mm
Rod treatment	Cataphoresis	Cataphoresis	Stainless steel	Cataphoresis	Cataphoresis	Stainless steel
Rod fixing	3 bolts	3 bolts	3 bolts	3 bolts	3 bolts	3 bolts

	RANCH B 219/700	RANCH B 219/700 - RAL	RANCH B 219/700 I	RANCH B 219/700 L	RANCH B 219/700 L - RAL	RANCH B 219/700 LI
Operator type	Fixed bollards	Fixed bollards	Fixed bollards	Fixed bollards	Fixed bollards	Fixed bollards
Rod height	700 mm	700 mm	700 mm	700 mm	700 mm	700 mm
Rod diameter	219 mm	219 mm	219 mm	219 mm	219 mm	219 mm
Rod thickness	5 mm	5 mm	5 mm	5 mm	5 mm	5 mm
Rod treatment	Cataphoresis	Cataphoresis	Stainless steel	Cataphoresis	Cataphoresis	Stainless steel
Rod fixing	3 bolts	3 bolts	3 bolts	3 bolts	3 bolts	3 bolts



# RANCH B



## Parking and traffic bollards

### RECOMMENDED ACCESSORIES

	<b>P800104 - ALLU</b>			
	Power supply for fixed Ranch E bollards			



## Parking and traffic bollards

# What is U-Link?

The technology that gives you more power

U-Link, Universal Link, is an exclusive BFT platform that can be used to create high-tech ecosystems. In Home Access Automation, it can be used to communicate with all home access automation devices of any brand. This saves you time and allows you to control everything easily and without any worries.

### It is intuitive

Easy to install and to use

### It is scalable

You can add as many devices as you want

### It is flexible

It allows you to create groups of interconnected products

### It is practical

Works with or without an internet connection

### It is functional

Its settings can be controlled remotely using dedicated applications



## Parking and traffic bollards

# Everything on one screen: find out more about this amazing technology

A world-exclusive platform that **can be used to create high-tech ecosystems** offering a vast range of solutions for many different sectors.

This proprietary platform which is a key feature of BFT products, thanks to the B-EBA cards and the Clonix U-Link receiver, is suitable for any protocol or product for access automation (including BFT products non-BFT ones and older versions) and it can be used in a variety of different sectors. This means any device becomes a smart device which can be interconnected with other systems, using a language that is becoming universal.



### U-Control HOME

U-Control HOME is the application that allows you to open the gate to your home and to remotely control BFT automations using your own smartphone. The iOS version can be used to automatically open the automation when you are close to it.



### U-Base 2

A software package for installation, performing maintenance and identifying any faults in the U-Link compatible operators, easily and conveniently.



### U-SDK

U-SDK is the application which allows BFT automations to be made compatible and easily integrated with a BMS network.



### Clonix U-Link

Connect non-native U-Link and non-BFT products to U-Link systems.

Is it possible to connect non-native U-Link BFT operators or other brands of products to U-Link? Yes, thanks to the Clonix receivers. Accessories which accept no limits.



### B-EBA

A direct link to your operators.

The B-EBA expansion cards make it possible to connect external devices such as PCs, smartphones and tablets to a BFT operator and a Clonix receiver or to connect multiple BFT products in a U-Link network. These accessories integrate with U-Link technology and with Bluetooth, Wifi, Z-Wave and TCP/IP protocols as well as with the RS485 serial interface. A device that demonstrates exactly what BFT means by interconnectivity.

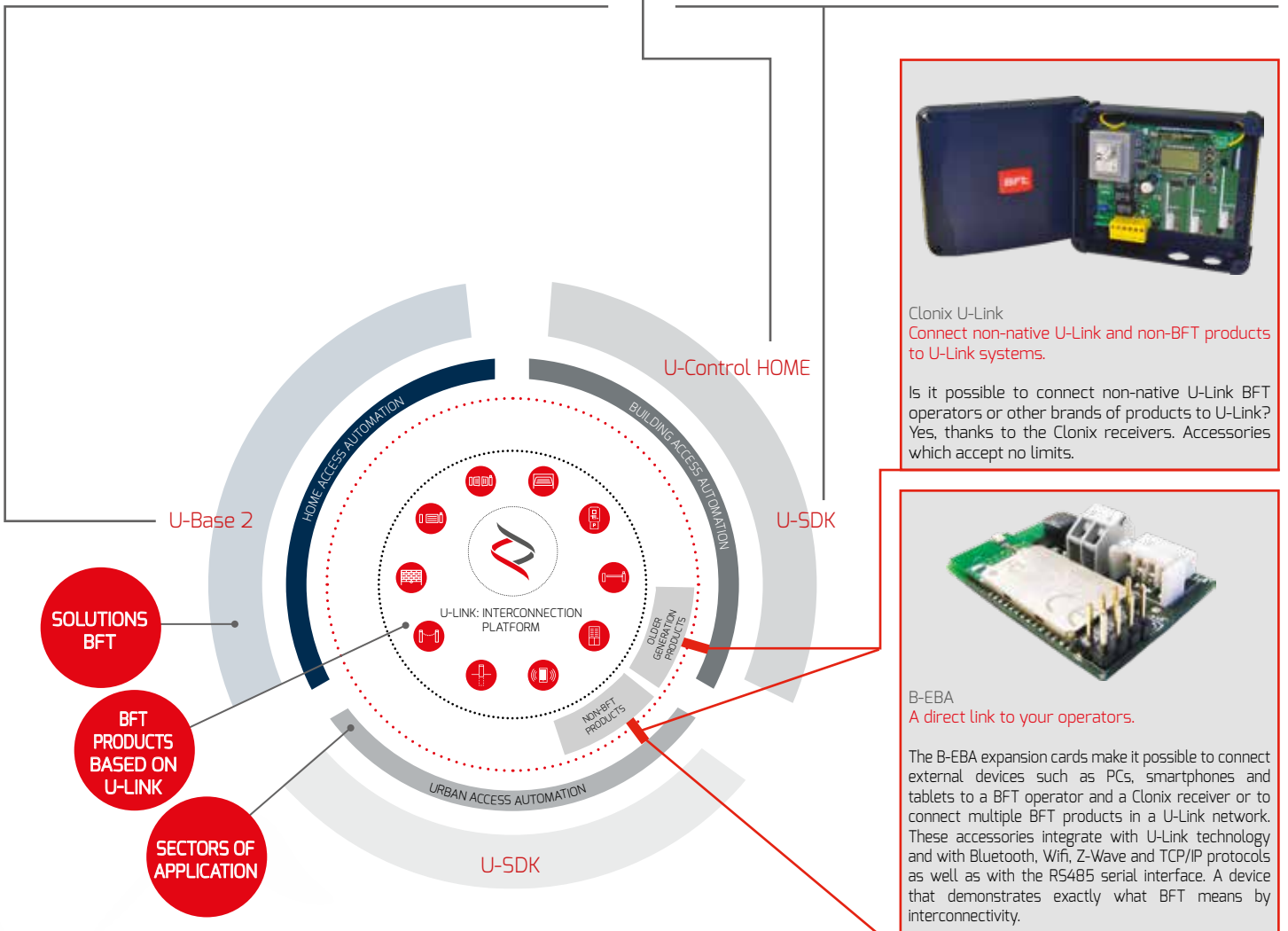



INFORMATION REGARDING THE PROTECTION OF THE INDUSTRIAL AND INTELLECTUAL PROPERTY RIGHTS OF BFT. BFT S.p.A. protects its industrial property by depositing trademarks, patents, models and designs. The intellectual property of BFT S.p.A. is protected by copyright law. BFT S.p.A. also protects its know-how by taking measures to protect the technical and commercial information inherent in its company and products. All the products in this catalogue are ORIGINAL BFT MODELS and only BFT S.p.A. is authorised to produce them and market them anywhere in the world. All the commercial names in this catalogue are owned by BFT S.p.A., and only BFT S.p.A. is authorised to use them in relation to the corresponding merchandise category. FALSIFIERS WILL BE PROCEEDED AGAINST IN ACCORDANCE WITH BOTH CIVIL AND CRIMINAL LAW. THESE CONDITIONS NOT ONLY GUARANTEE THE INTELLECTUAL PROPERTY RIGHTS OF BFT, BUT ALSO PROTECT CUSTOMERS BY GUARANTEEING THAT THE PRODUCTS THEY ARE PURCHASING ARE ORIGINAL BFT PRODUCTS RESULTING FROM STUDIES AND DESIGNS WITHIN THE BFT COMPANY.